

Surname	Centre Number	Candidate Number
Other Names		0



GCSE – NEW

3410UB0-1



**CHEMISTRY – Unit 2:
Chemical Bonding, Application of Chemical Reactions
and Organic Chemistry**

HIGHER TIER

THURSDAY, 17 MAY 2018 – MORNING

1 hour 45 minutes

For Examiner's use only		
Question	Maximum Mark	Mark Awarded
1.	8	
2.	12	
3.	8	
4.	9	
5.	11	
6.	7	
7.	9	
8.	9	
9.	7	
Total	80	

3410UB01
01

ADDITIONAL MATERIALS

In addition to this examination paper you will need a calculator and a ruler.

INSTRUCTIONS TO CANDIDATES

Use black ink or black ball-point pen. Do not use gel pen or correction fluid.

Write your name, centre number and candidate number in the spaces at the top of this page.

Answer **all** questions.

Write your answers in the spaces provided in this booklet. If you run out of space, use the additional page at the back of the booklet, taking care to number the question(s) correctly.

INFORMATION FOR CANDIDATES

The number of marks is given in brackets at the end of each question or part-question.

Question **5(a)** is a quality of extended response (QER) question where your writing skills will be assessed.

The Periodic Table is printed on the back cover of this paper and the formulae for some common ions on the inside of the back cover.



MAY183410UB0101

Answer all questions.

1. (a) Hydrochloric acid, HCl, reacts with sodium hydroxide solution to form sodium chloride and water only.

Write a balanced **symbol** equation for this reaction.

[2]

- (b) A group of students was asked to find the volume of hydrochloric acid solution needed to neutralise 25.0 cm³ of sodium hydroxide solution. They decided to titrate sodium hydroxide with hydrochloric acid.

Apparatus

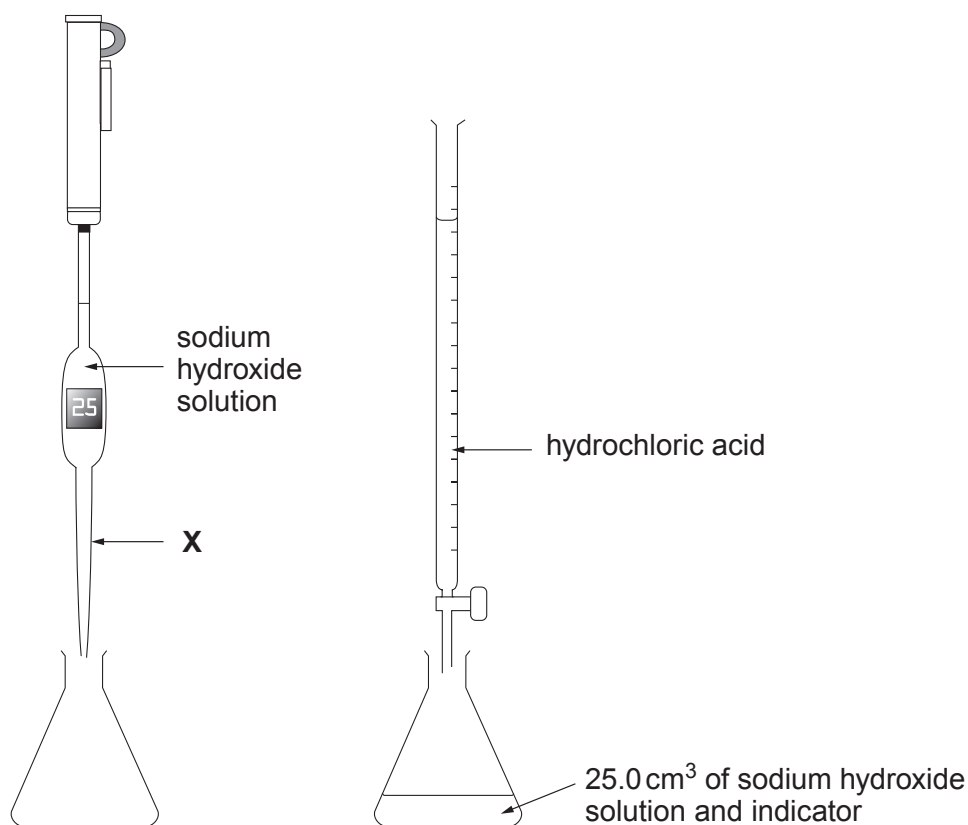

Results

Titre	1	2	3
Volume of hydrochloric acid needed (cm ³)	18.2	17.8	18.0



- (i) Name the piece of apparatus **X**. [1]

.....

- (ii) Explain the purpose of the indicator. [1]

.....

- (iii) Calculate the mean volume of hydrochloric acid needed to neutralise 25.0 cm^3 of the sodium hydroxide solution. [1]

Mean volume = cm^3

- (iv) The change in temperature during the reaction can be monitored using a temperature sensor.

Sketch a graph on the axes below to show how the temperature changes as more and more acid up to a total of 30 cm^3 is added. [2]

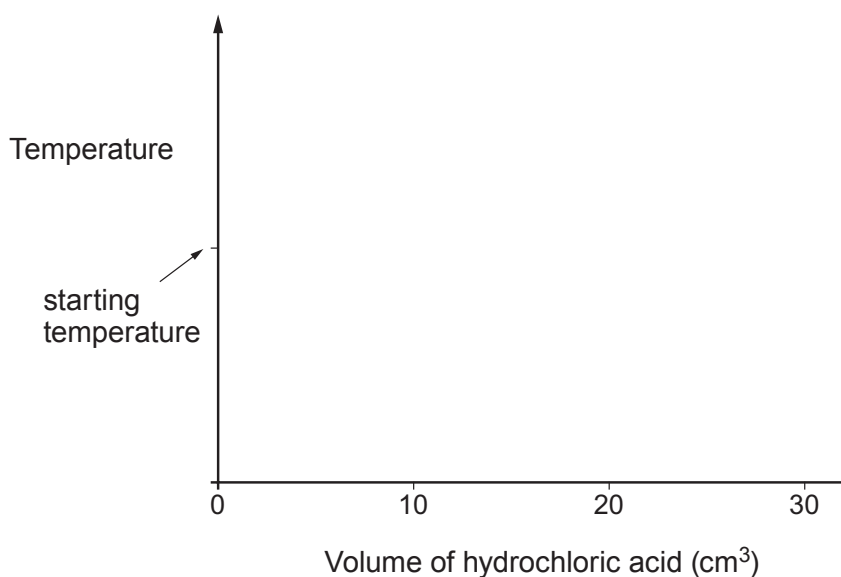

- (v) The experiment was repeated using hydrochloric acid of **half** the original concentration.

State the volume of hydrochloric acid that would be needed to change the indicator colour. [1]

Volume = cm^3



2. (a) When a mixture of iron(III) oxide and aluminium powder (Thermit mixture) is heated, there is a violent reaction. The reaction is carried out in a tube surrounded by a mound of sand because the temperature reaches 2500 °C. A bead of iron is recovered from the sand. The picture below shows the reaction taking place in a darkened room.



- (i) Give the reason why the iron formed in the reaction is molten. [1]

.....

- (ii) Complete and balance the **symbol** equation for this reaction. [2]



- (iii) State which of the substances is oxidised. Give the reason for your choice. [1]

.....

- (iv) When a mixture of magnesium oxide and aluminium powder is heated, there is no reaction.

List iron, magnesium and aluminium in order of reactivity. [1]

Most reactive

.....

Least reactive



- (b) Some metals are more reactive than others. A more reactive metal displaces a less reactive metal from its compounds.

A student was given tin, iron, copper and zinc and solutions of the metal sulfates. Using a dropping pipette, she put a little of one of the sulfate solutions in four of the depressions of the dropping tile. She did this for each solution in turn. She then put a piece of metal foil in each of the solutions, as shown below.

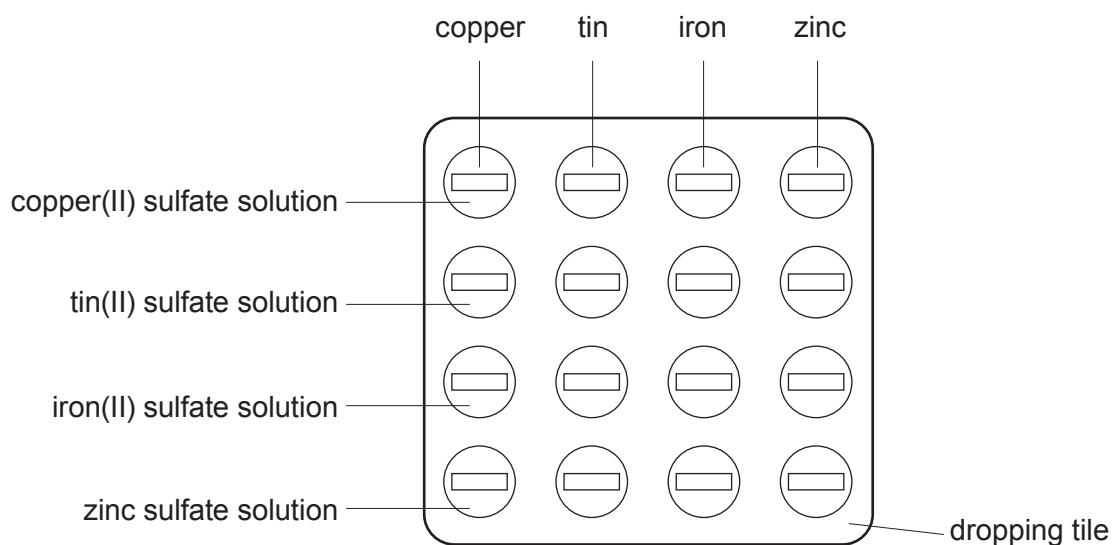

- (i) Put a tick (✓) next to the question which **best** describes the investigation the student is carrying out. [1]

Which displacement is the most exothermic?

Which metal can displace copper from solution?

What is meant by the reactivity series?

What are the positions of the four metals in the reactivity series?



- (ii) The student recorded the results by putting a tick (✓) next to a mixture which showed signs of a reaction and a cross (X) next to a mixture which showed no signs of a reaction.

The student concluded that:
 tin displaces copper
 iron displaces tin
 iron displaces copper
 zinc displaces iron

Give the **letter** of the tile below which shows the results she recorded. [1]

Letter

	copper	tin	iron	zinc
copper(II) sulfate solution	✓	✓	✓	✓
tin(II) sulfate solution	X	✓	✓	✓
iron(II) sulfate solution	X	X	✓	X
zinc sulfate solution	X	X	X	✓

A

	copper	tin	iron	zinc
copper(II) sulfate solution	X	✓	✓	✓
tin(II) sulfate solution	✓	X	X	X
iron(II) sulfate solution	✓	✓	X	X
zinc sulfate solution	✓	✓	✓	X

B

	copper	tin	iron	zinc
copper(II) sulfate solution	X	X	X	X
tin(II) sulfate solution	✓	✓	X	X
iron(II) sulfate solution	✓	✓	X	X
zinc sulfate solution	✓	✓	✓	X

C

	copper	tin	iron	zinc
copper(II) sulfate solution	X	✓	✓	✓
tin(II) sulfate solution	X	X	✓	✓
iron(II) sulfate solution	X	X	X	✓
zinc sulfate solution	X	X	X	X

D

- (iii) Another student said that not all of the tests were necessary. Give **one** example of a test not needed. Explain your choice. [2]

Example

Explanation

.....



(c) Copper displaces silver from a solution of silver nitrate, AgNO_3 , to form copper(II) nitrate solution.

(i) Describe **one** change the student would **see** during this displacement reaction. [1]

.....

.....

(ii) Write a balanced **symbol** equation for this reaction. [2]

.....

12



3. (a) The bar chart shows the relative *supply* and *demand* for some fractions obtained from crude oil.

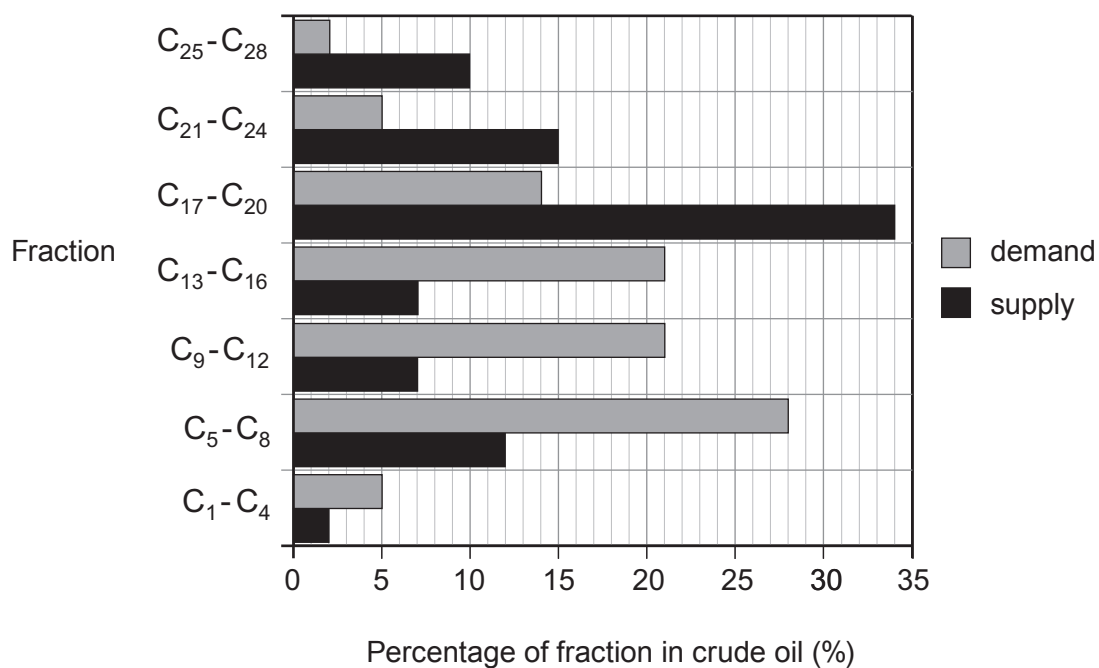

- (i) Use the bar chart to describe how the **difference** between *supply* and *demand* of the fractions changes as chain length increases. [2]

.....

.....

.....

.....

.....



- (ii) Oil companies have solved the problem of the over-supply of some fractions by using a process called cracking.

$C_{14}H_{30}$ can be cracked forming hexene, ethene and hydrocarbon **A**.

- I. Complete the equation for the cracking of $C_{14}H_{30}$. [1]

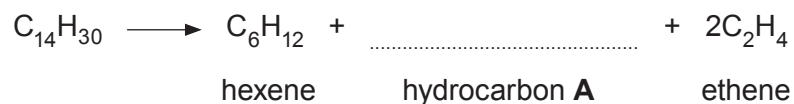

- II. Name hydrocarbon **A**. [1]

- III. State why ethene is considered an important raw material. [1]
-
-

- (iii) One hydrocarbon found in the C_1 - C_4 fraction is propane. Propane burns in air forming carbon dioxide and water.

Balance the symbol equation that represents this reaction. [1]



- (b) Shale gas is natural gas trapped in rocks deep underground. Like oil and coal, shale gas has, essentially, formed from the remains of plants, animals and micro-organisms that lived millions of years ago. It can be extracted using a process known as hydraulic fracturing – or “fracking” – which involves drilling long horizontal wells into the rocks more than a kilometre below the surface. Massive quantities of water, sand and chemicals are pumped into the wells at high pressure. This opens up cracks in the shale, which are held open by the sand, enabling the trapped gas to escape to the surface for collection.

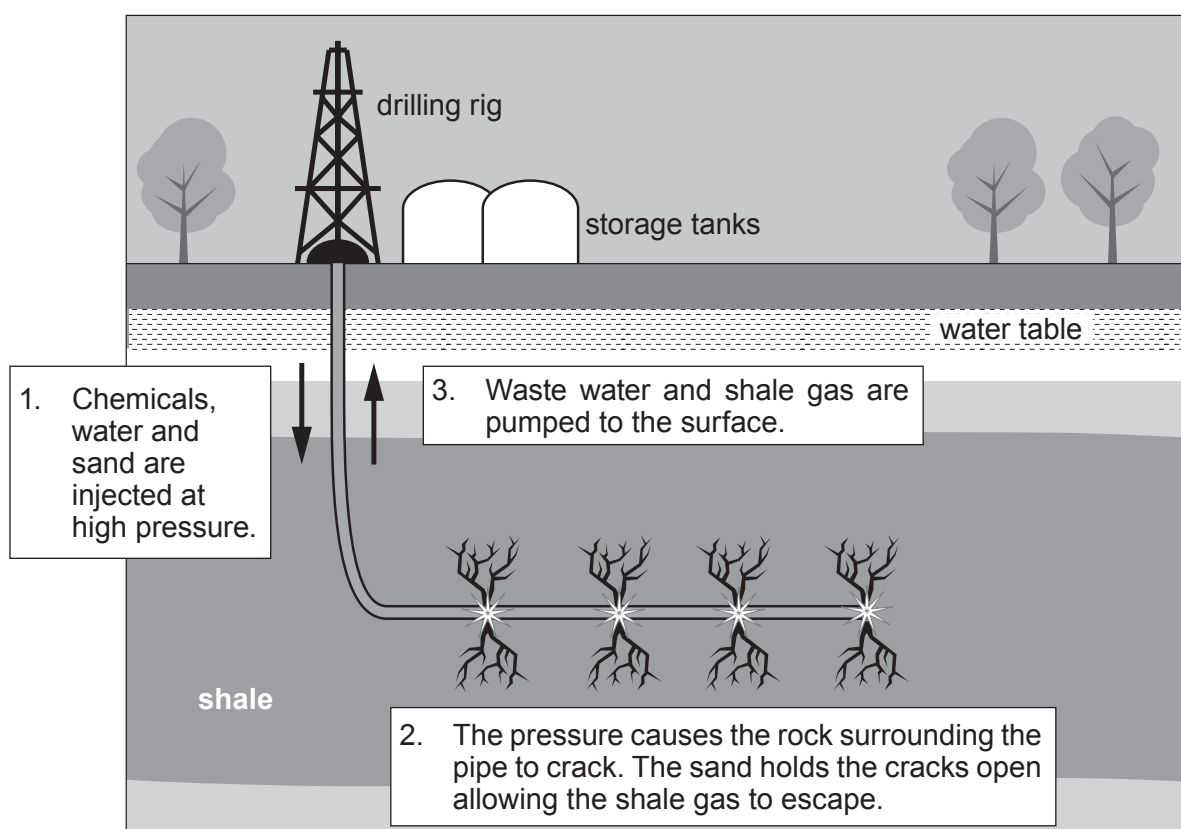

Supporters of fracking argue that extracting shale gas deposits will help keep energy affordable and cut consumption of dirtier coal. But opponents claim fracking is dangerous and polluting, and that tapping into extra shale gas supplies will increase carbon dioxide emissions. The main controversy surrounding shale gas is the potential of fracking to contaminate drinking water supplies with shale gas or drilling chemicals. Other issues include the huge quantities of water and chemicals used in the extraction process, the waste water generated and possible earthquake tremors.



- (i) Put a tick (✓) in the box next to the statement that identifies the substance(s) recovered during the fracking process. [1]

only shale gas

shale gas and contaminated water

shale gas and sand

shale gas, sand and toxic chemicals

- (ii) Put a tick (✓) in the box next to the statement which is true. [1]

burning shale gas does not cause global warming

chemicals used in fracking are contaminating our drinking water

fracking produces vast quantities of contaminated water

shale gas is a renewable energy source

shale gas is cheaper than other fossil fuels



4. (a) Calcium and oxygen react forming calcium oxide.

- (i) Explain, using dot and cross diagrams, how bonding takes place during the formation of calcium oxide. [2]

(ii)

Substance	Melting point ($^{\circ}\text{C}$)
calcium oxide	2613
sodium chloride	801

Explain why both of these compounds have high melting points and why the melting point of calcium oxide is higher. [2]

.....

.....

.....

.....



(b) Graphene and graphite are different forms of carbon.

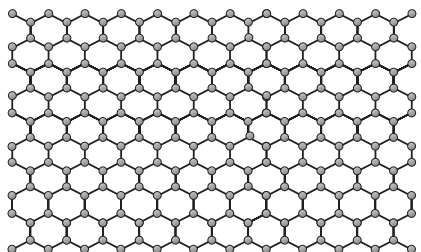

graphene

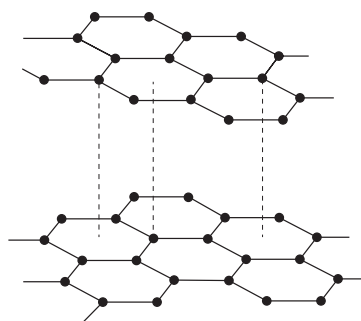

graphite

(i) Explain how the bonding present in both forms makes them good conductors of electricity. [2]

.....

.....

.....



(ii) Carbon nanotubes can be formed by rolling up graphene sheets.

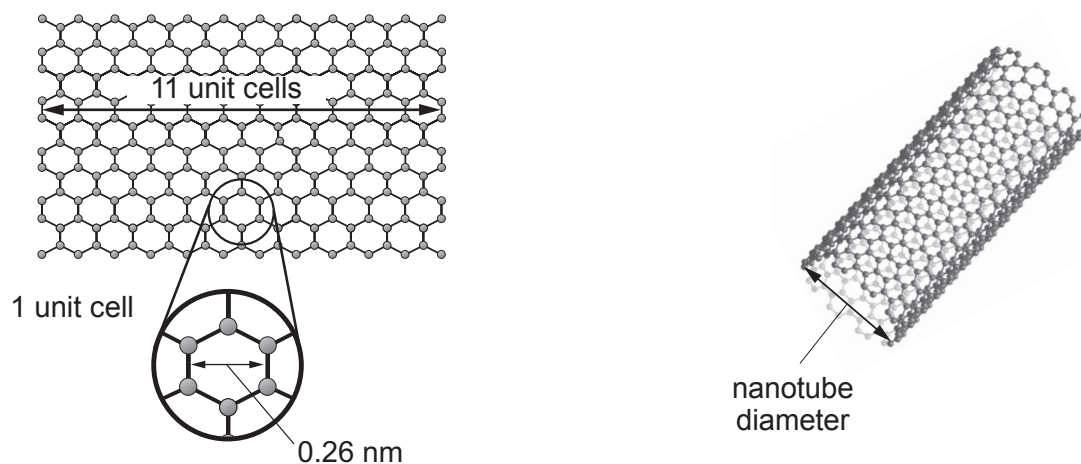

A sheet of graphene 11 unit cells in width was rolled up to form a nanotube. Use the information below to calculate the diameter, in metres, of the nanotube formed. Write your answer in **standard form**. [3]

$$\text{circumference} = \pi \times \text{diameter}$$

$$\pi = 3.14$$

$$1 \text{ nm} = 1 \times 10^{-9} \text{ m}$$

Diameter = m



BLANK PAGE

**PLEASE DO NOT WRITE
ON THIS PAGE**



- (b) The equation shows the bonds which are broken and the bonds which are formed in the production of sulfur trioxide.

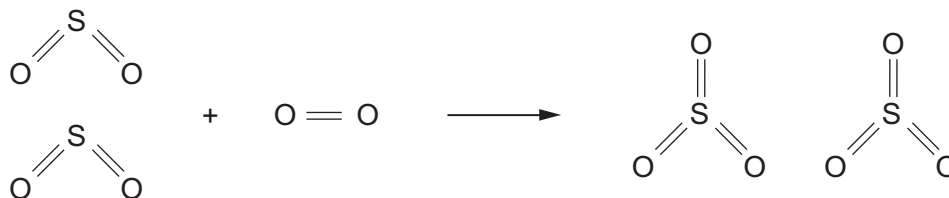

The bond energy of an S=O bond is 523 kJ.

- (i) The **total** energy needed to break the bonds in the reactants is 2587 kJ. Calculate the energy needed to break an O=O bond. [2]

Energy = kJ

- (ii) Calculate the overall energy change for the reaction. [2]

Overall energy change = kJ

- (iii) Complete the energy profile for the reaction. [1]

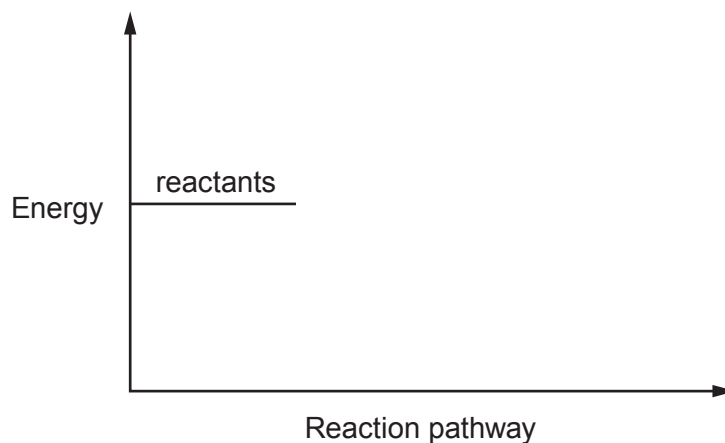

6. (a) Fertilisers usually contain compounds of three essential elements required for healthy and productive plant growth. The table shows the properties of two nitrogenous fertilisers.

Property	Ammonium nitrate	Urea
% nitrogen	34	46
Mass of fertiliser absorbed by plants per 2000 litre spreader (kg)	690	560
Solubility	very soluble	very soluble
Cost (£/tonne)	360	350
Loss of ammonia due to evaporation	low	high
Weather dependency	effective in all conditions	effectiveness dependent on specific temperature and rainfall conditions

- (i) Which fertiliser leads to the absorption of more **nitrogen** from a full 2000 litre spreader? Show your working. [2]

Fertiliser

- (ii) Urea is the most widely used fertiliser in the world. However, many British farmers prefer to use ammonium nitrate.

Put a tick (✓) in the box next to the statement which suggests the **main** reason for this. [1]

ammonium nitrate contains less nitrogen than urea

ammonium nitrate is better suited to British weather conditions than urea

more ammonium nitrate is absorbed by plants than urea

ammonium nitrate is more expensive than urea



- (b) The flow chart shows the chemical tests for the identification of the ions present in ammonium sulfate, $(\text{NH}_4)_2\text{SO}_4$.

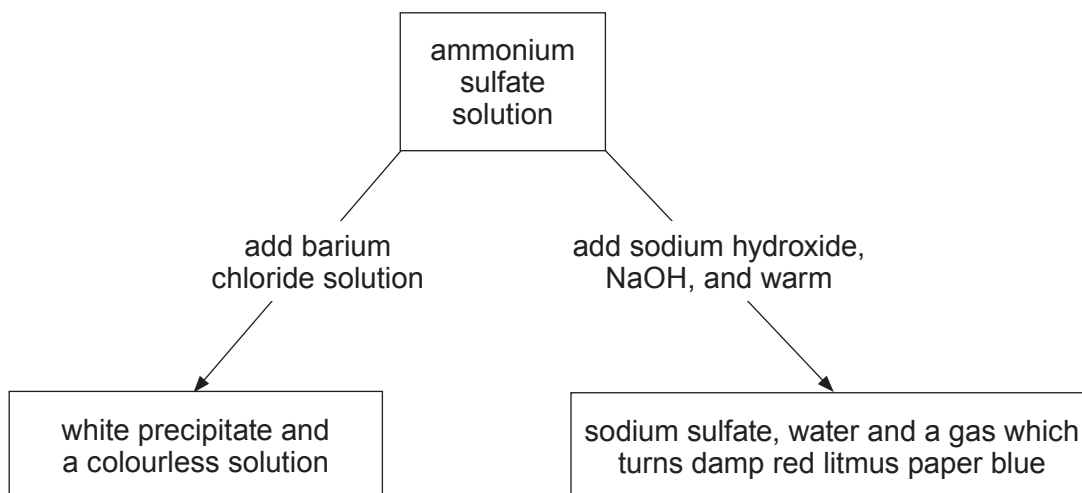

- (i) Write a balanced **symbol** equation for the reaction between ammonium sulfate and sodium hydroxide. [2]

- (ii) The symbol equation below represents the reaction occurring between ammonium sulfate solution and barium chloride solution.



Write the **ionic** equation for the reaction. Include the state symbols. [2]



7. (a) The table shows the first four members of the alkane family.

Alkanes
methane, CH ₄
ethane, C ₂ H ₆
propane, C ₃ H ₈
butane, C ₄ H ₁₀

Give the **general** formula for the alkane family.

[1]

.....

- (b) C₄H₁₀ has two isomers. The diagram below shows the structure of one of the isomers, butane.

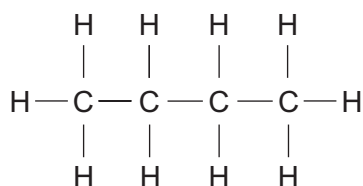

Draw and name the other isomer.

[2]

Isomer structure

Name of isomer



(c) The flow diagram shows two reactions of propene.

Draw the structural formula for compound **A** and the repeating unit in polymer **B**. [2]

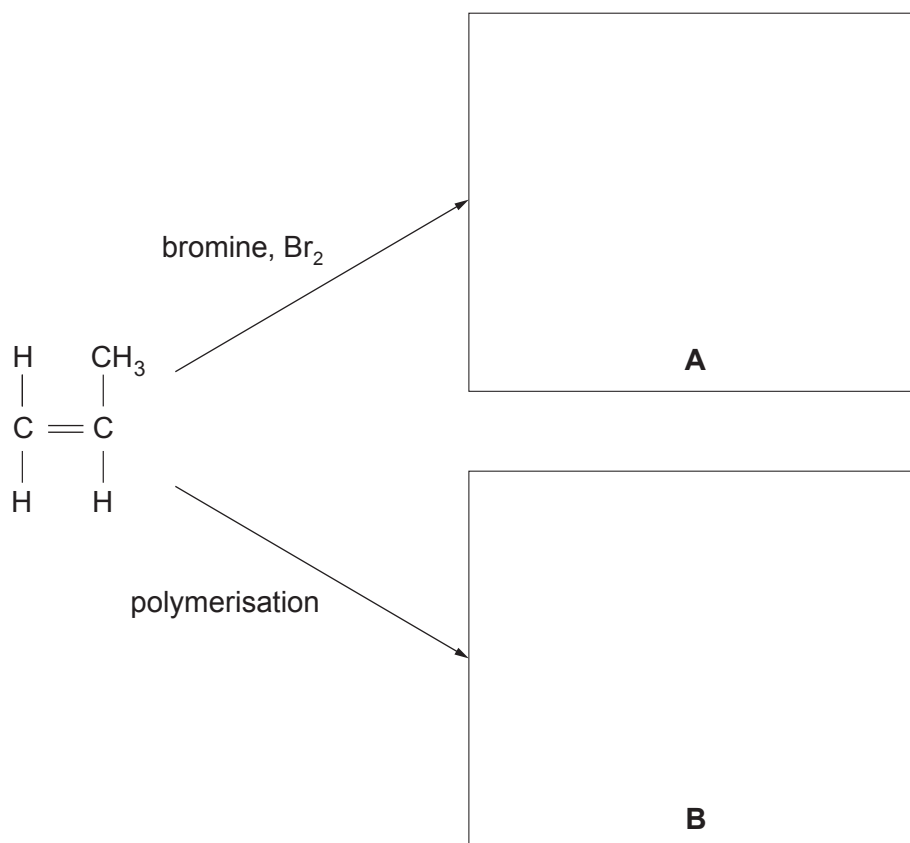

(d) A student was given a colourless liquid. He suspects the liquid is ethanol.

Describe a chemical test that he could carry out to positively identify the liquid as ethanol. Include the observation he would make. [2]

Test

Observation



(e) Organic compounds can also be identified using infrared spectroscopy.

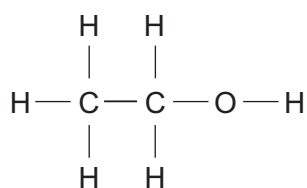

ethanol

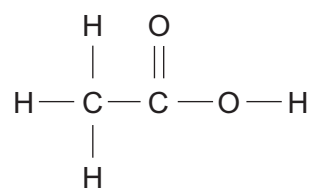

ethanoic acid

Bond	Wavenumber (cm^{-1})
C=O	1650 to 1750
C—H	2800 to 3100
O—H	2500 to 3550

The infrared spectra of ethanol, ethanoic acid and one other compound are shown on the opposite page.

Use the information in the table to identify the spectra belonging to ethanol and ethanoic acid. [2]

Ethanol

Ethanoic acid



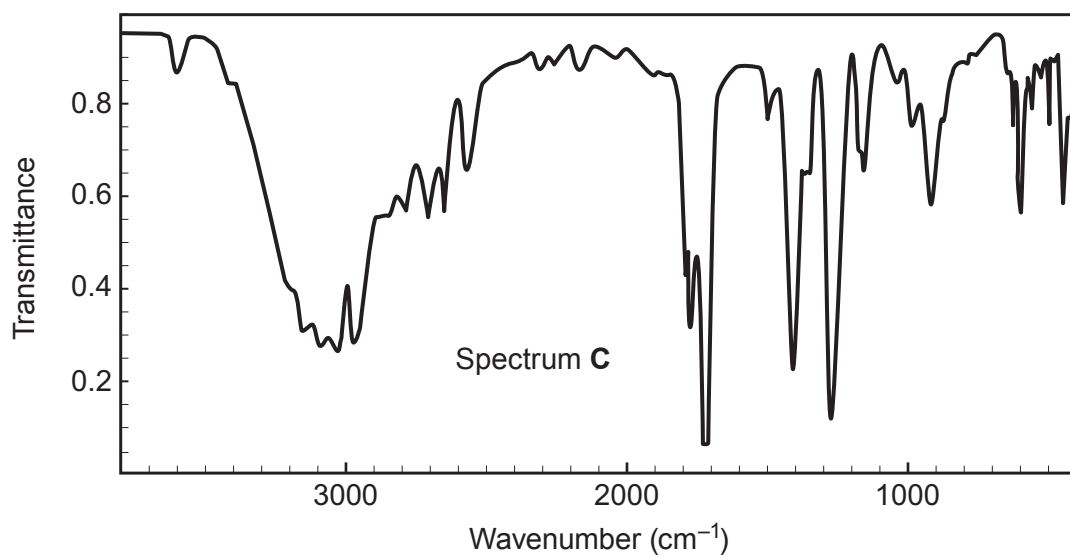
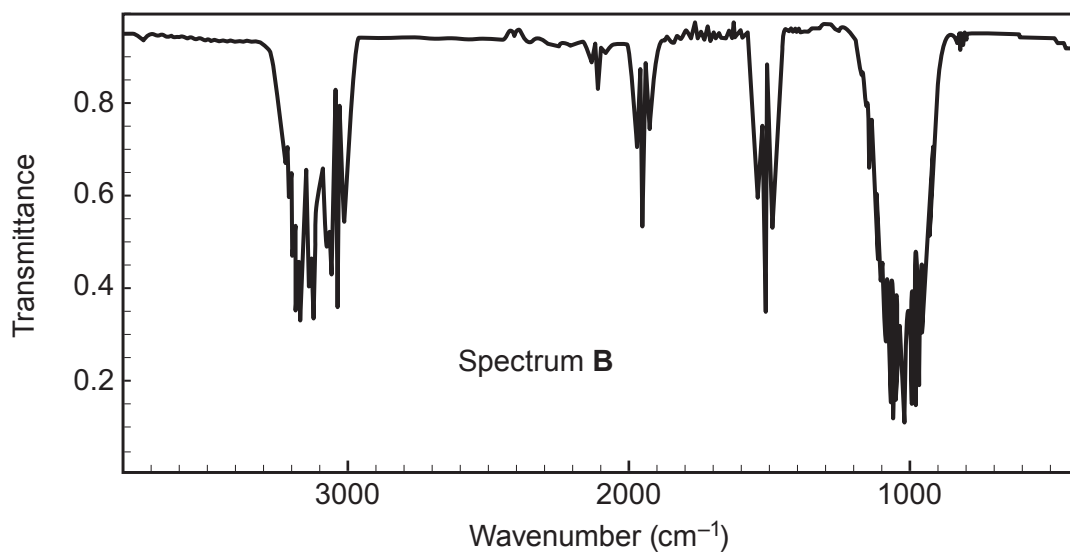
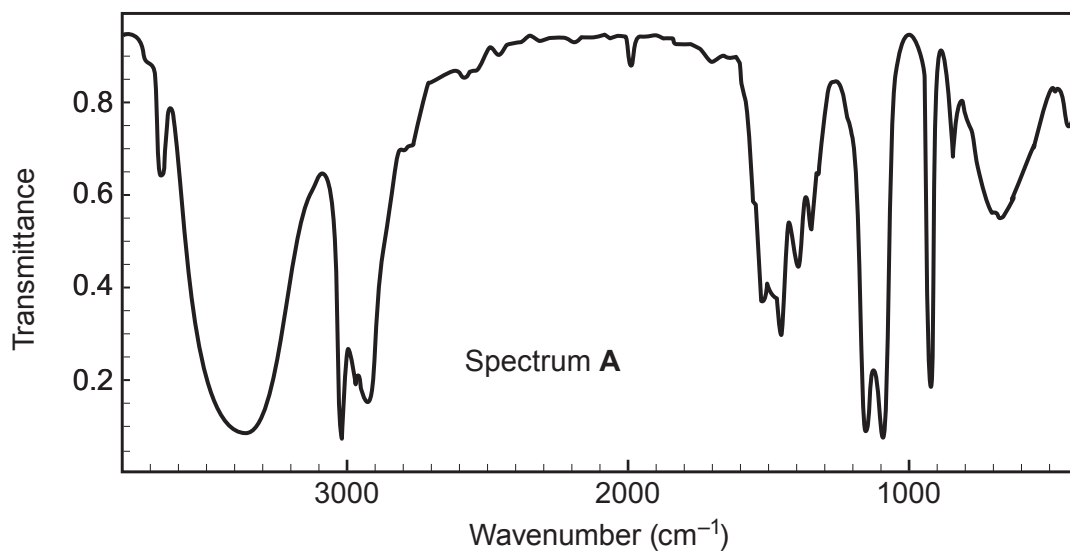

8. A student used the apparatus shown to investigate how changing current affects the mass of copper deposited on the cathode.

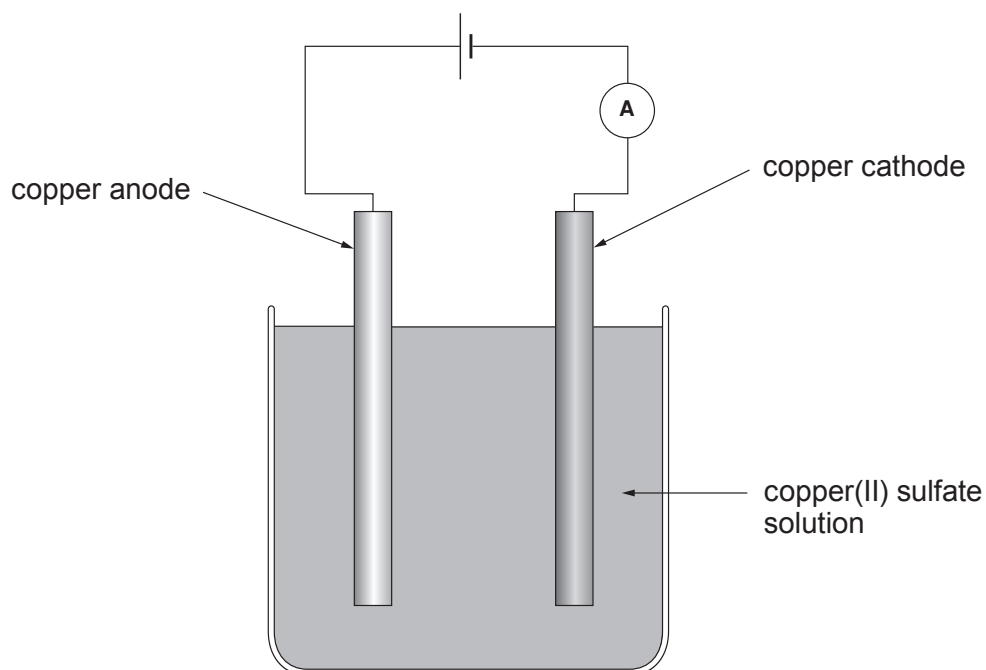

Equal volumes and concentrations of copper(II) sulfate solution were used each time. Each experiment was run for 10 minutes. All the readings were obtained at room temperature. The following procedure was followed before the mass of copper could be found.

- the electrode was carefully removed from the electrolyte
- the copper deposit was washed
- the electrode and copper deposit were dried

Her results are shown in the following table.

Current (A)	Mass of copper deposited (g)
0.0	0.00
0.5	0.16
1.0	0.30
1.5	0.43
2.0	0.60



- (a) Choose suitable scales for the axes below and plot the current against the mass of copper deposited. Draw a suitable line. [4]

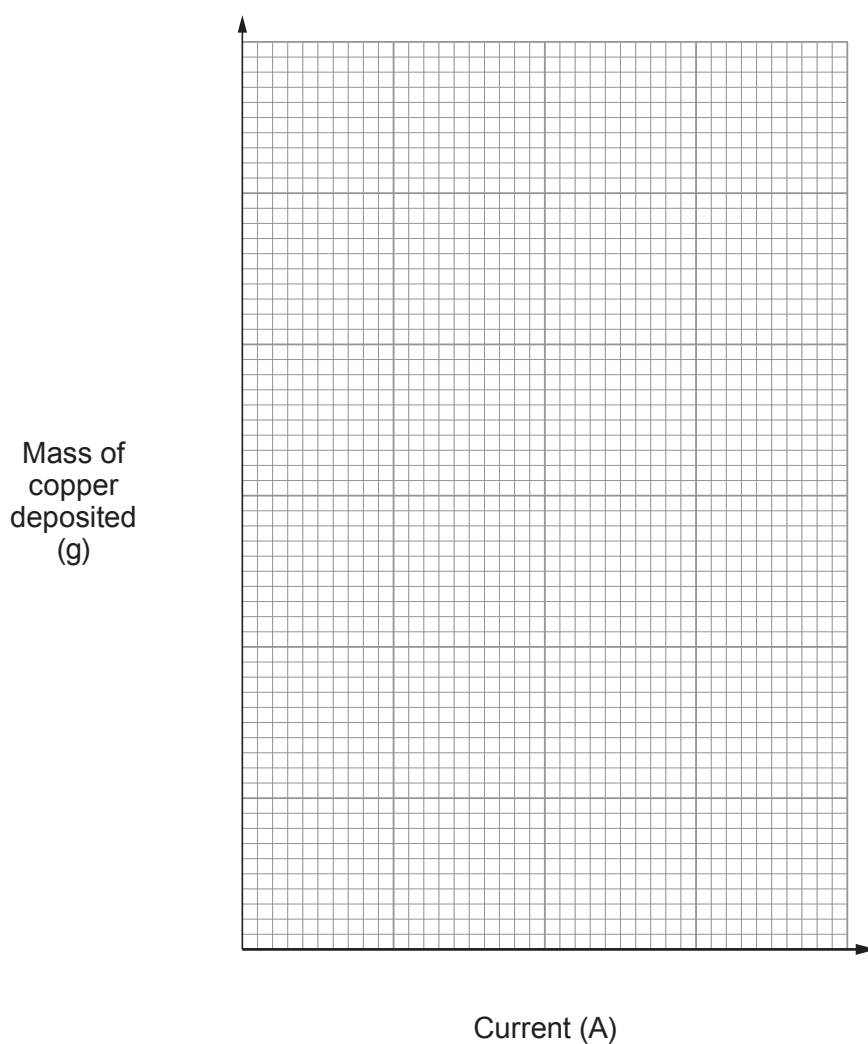

- (b) Use your graph to predict the mass of copper deposited using a current of 3.5 A. [1]

Mass of copper deposited = g



- (c) Explain why the electrolyte keeps its blue colour during the electrolysis process. Include electrode equations to support your answer. [4]

.....

.....

.....

.....

.....

.....

9



9. Indigestion is caused by excess hydrochloric acid in the stomach. The calcium carbonate in an antacid tablet neutralises the excess acid.

Calcium carbonate reacts with hydrochloric acid according to the equation below.

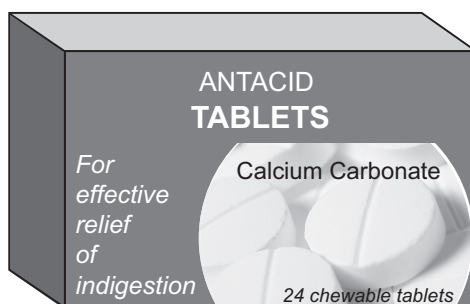

To determine how much calcium carbonate is present, a crushed indigestion tablet was mixed with water and titrated with dilute hydrochloric acid of concentration 1.0 mol/dm^3 . The end-point was determined using the indicator phenolphthalein. The procedure was repeated three times and the mean volume of hydrochloric acid solution needed to neutralise one tablet was found to be 15.2 cm^3 .

- (a) Calculate the number of moles of hydrochloric acid in 15.2 cm^3 of the 1.0 mol/dm^3 solution. [2]

Number of moles = mol

- (b) Calculate the number of moles of calcium carbonate in one tablet. [1]

Number of moles = mol



- (c) Calculate the mass of calcium carbonate in one tablet. Give your answer in **milligrams, mg**. [3]

$$A_r(\text{Ca}) = 40 \quad A_r(\text{C}) = 12 \quad A_r(\text{O}) = 16$$

Mass of calcium carbonate = mg

- (d) The diagram shows the labelling on the packet of indigestion tablets.

Each tablet contains:

calcium carbonate	680 mg
magnesium carbonate	80 mg
sucrose and glucose	250 mg
flavouring	
talc	
saccharin	
sodium and magnesium stearate	

Suggest an explanation for the difference between your answer in part (c) and the information given on the packet. [1]

.....

.....

END OF PAPER



BLANK PAGE

**PLEASE DO NOT WRITE
ON THIS PAGE**



FORMULAE FOR SOME COMMON IONS

POSITIVE IONS		NEGATIVE IONS	
Name	Formula	Name	Formula
aluminium	Al^{3+}	bromide	Br^-
ammonium	NH_4^+	carbonate	CO_3^{2-}
barium	Ba^{2+}	chloride	Cl^-
calcium	Ca^{2+}	fluoride	F^-
copper(II)	Cu^{2+}	hydroxide	OH^-
hydrogen	H^+	iodide	I^-
iron(II)	Fe^{2+}	nitrate	NO_3^-
iron(III)	Fe^{3+}	oxide	O^{2-}
lithium	Li^+	sulfate	SO_4^{2-}
magnesium	Mg^{2+}		
nickel	Ni^{2+}		
potassium	K^+		
silver	Ag^+		
sodium	Na^+		
zinc	Zn^{2+}		





THE PERIODIC TABLE

Group

1 2 3 4 5 6 7 0

1 H Hydrogen 1																	4 He Helium 2
7 Li Lithium 3	9 Be Beryllium 4															19 F Fluorine 9	20 Ne Neon 10
23 Na Sodium 11	24 Mg Magnesium 12															35.5 Cl Chlorine 17	40 Ar Argon 18
39 K Potassium 19	40 Ca Calcium 20	45 Sc Scandium 21	48 Ti Titanium 22	51 V Vanadium 23	52 Cr Chromium 24	55 Mn Manganese 25	56 Fe Iron 26	59 Co Cobalt 27	59 Ni Nickel 28	63.5 Cu Copper 29	65 Zn Zinc 30	70 Ga Gallium 31	73 Ge Germanium 32	75 As Arsenic 33	79 Se Selenium 34	80 Br Bromine 35	84 Kr Krypton 36
86 Rb Rubidium 37	88 Sr Strontium 38	89 Y Yttrium 39	91 Zr Zirconium 40	93 Nb Niobium 41	96 Mo Molybdenum 42	99 Tc Technetium 43	101 Ru Ruthenium 44	103 Rh Rhodium 45	106 Pd Palladium 46	108 Ag Silver 47	112 Cd Cadmium 48	115 In Indium 49	119 Sn Tin 50	122 Sb Antimony 51	128 Te Tellurium 52	127 I Iodine 53	131 Xe Xenon 54
133 Cs Caesium 55	137 Ba Barium 56	139 La Lanthanum 57	179 Hf Hafnium 72	181 Ta Tantalum 73	184 W Tungsten 74	186 Re Rhenium 75	190 Os Osmium 76	192 Ir Iridium 77	195 Pt Platinum 78	197 Au Gold 79	201 Hg Mercury 80	204 Tl Thallium 81	207 Pb Lead 82	209 Bi Bismuth 83	210 Po Polonium 84	210 At Astatine 85	222 Rn Radon 86
223 Fr Francium 87	226 Ra Radium 88	227 Ac Actinium 89															

Key

