

Year 11 Double Award Science

Chemistry

Revision Booklet

(exam date: Thursday 16th May PM)

Name

Please use test results, feedback and self-assessment to colour code each section red, amber or green, and ensure that where you need to do extra work to improve, you use Prep time to do so.

| | Understood | Revised |
|-----------------------------------------------------------------------------------------------------------------------|------------|---------|
| 5.1 BONDING, STRUCTURE AND PROPERTIES | | |
| Properties and structure of metals | | |
| Properties and structure of simple molecular covalent substances | | |
| Properties and structure of ionic compounds | | |
| Properties and structure of giant covalent substances (diamond, graphite, fullerenes, carbon nano-tubes and graphene) | | |
| Properties and uses of nano-scale particles | | |
| Properties and uses of smart materials | | |
| | | |
| 5.2 ACIDS, BASES AND SALTS | | |
| What are acids and bases | | |
| The pH scale | | |
| Reaction of dilute acids with metals | | |
| Neutralisation of dilute acids with bases | | |
| Neutralisation of dilute acids with carbonates | | |
| Test for carbonate ions | | |
| preparation of crystals of soluble salts | | |
| Names of salts | | |
| Titration to prepare soluble salts | | |
| | | |
| 5.3 METALS AND THEIR EXTRACTION | | |
| What are ores | | |
| The reactivity series | | |
| Reduction and oxidation | | |
| The blast furnace | | |
| Electrolysis of molten ionic compounds | | |
| Electrolysis of aluminium oxide | | |
| Properties and uses of iron, aluminium, copper and titanium | | |
| Alloys | | |
| Pros and cons of mining and extracting ores | | |
| | | |
| 5.4 CHEMICAL REACTIONS AND ENERGY | | |
| Exothermic and endothermic reactions | | |
| Energy profiles | | |
| Calculating overall energy changes from bond energy | | |
| | | |
| 5.5 CRUDE OIL, FUELS AND ORGANIC CHEMISTRY | | |
| what is crude oil | | |
| Fractional Distillation | | |
| Trends, properties and uses of fractions | | |
| Pro and cons of the oil industry | | |
| Combustion of hydrocarbons | | |
| Fire triangle | | |
| Cracking of hydrocarbons | | |
| Alkanes and alkenes | | |
| Testing for alkenes | | |
| Polymerisation | | |
| Properties of plastics | | |
| Environmental issues of the disposal of plastics | | |
| | | |

UNIT 2 – CHEMICAL BONDING, APPLICATION OF CHEMICAL REACTIONS & ORGANIC CHEMISTRY

Contents

| | |
|----------------------------------------------------------------------------------------------------------------|-----------|
| Topic 1 - BONDING, STRUCTURE AND PROPERTIES..... | 2 |
| Metals and Non-metals | 2 |
| Metallic bonding..... | 3 |
| Ionic and covalent bonding | 4 |
| Simple and Giant structures | 8 |
| Carbon | 10 |
| Smart materials | 11 |
| Nano-materials..... | 12 |
| Topic 2 - ACIDS, BASES AND SALTS..... | 13 |
| Common acids and alkalis | 13 |
| Acid, Alkali or Neutral - The pH scale | 13 |
| Acids, Alkalis and Bases | 14 |
| Neutralisation | 14 |
| Reactions of acids..... | 15 |
| Summary of reactions of acids | 17 |
| Exothermic reactions..... | 18 |
| Sulfate test..... | 18 |
| Tests for gases | 18 |
| Preparation of salt crystals..... | 19 |
| Titration | 20 |
| pH curves..... | 21 |
| Preparing a salt crystals using titration then evaporation | 22 |
| GCSE Chemistry ONLY | |
| Concentration | 23 |
| Strong and weak acids..... | 25 |
| Reactions of acids - further | 26 |
| Precipitates..... | 27 |
| Making an insoluble compound | 27 |
| Topic 3 - METALS AND THEIR EXTRACTION..... | 28 |
| Where do metals come from?..... | 28 |
| Metal ores | 28 |
| Extracting metals..... | 29 |
| Displacement Reactions | 30 |
| Displacement Reactions – Oxidation / Reduction | 31 |
| Industrial extraction of iron..... | 32 |
| Electrolysis..... | 34 |
| Industrial extraction of aluminium..... | 35 |
| Factors affecting location of industrial plants..... | 36 |
| Properties and uses of common metals..... | 36 |
| Transition metals | 37 |
| GCSE Chemistry ONLY | |
| Identifying ions based on precipitate | 38 |
| Electrolysis – further | 39 |
| Manufacturing sodium hydroxide..... | 41 |
| Topic 4 - CHEMICAL REACTIONS AND ENERGY.. | 42 |
| Exothermic and Endothermic reactions | 42 |
| Activation energy..... | 42 |
| Energy profiles | 43 |
| Bonds and energy | 44 |
| Topic 5 - CRUDE OIL, FUELS AND ORGANIC CHEMISTRY..... | 46 |
| Environmental aspects | 46 |
| Fractional distillation | 47 |
| Combustion..... | 48 |
| The fire triangle..... | 49 |
| Cracking | 50 |
| Creating Plastics..... | 50 |
| Alkanes..... | 51 |
| Alkenes..... | 51 |
| Isomers | 52 |
| Reactions of Alkenes..... | 53 |
| GCSE Chemistry ONLY | |
| Ethanol and Alcohols..... | 57 |
| Health, Social and Economic impacts | 58 |
| Chemistry of Alcohols..... | 60 |
| Oxidation of alcohols | 61 |
| Infrared Spectroscopy | 62 |
| Topic 6 - REVERSIBLE REACTIONS, INDUSTRIAL PROCESSES AND IMPORTANT CHEMICALS (GCSE Chemistry ONLY)..... | 64 |
| Reversible reactions | 64 |
| Haber process – industrial manufacturing of ammonia | 64 |
| Contact process - industrial manufacturing of sulfuric acid | 66 |
| Identification of ammonia and ammonium .. | 69 |
| Table of Ions..... | 70 |
| Periodic Table of Elements | 71 |

Metallic bonding

Why do metals behave differently to non-metals and compounds? It's due to their **metallic bonding**.

The properties of all materials, are determined by:

- the types of atoms present;
- the types of bonding between the atoms;
- and the way the atoms are packed together;

Metals are giant structures with a "sea" of **free electrons**. Metallic bonds are strong, so metals can maintain a regular structure and usually have **high melting** and **boiling points**.

Outer shell electrons of metals are **free to move**. The strength of a metallic bond is the force of attraction between the metal ions and free moving electrons.

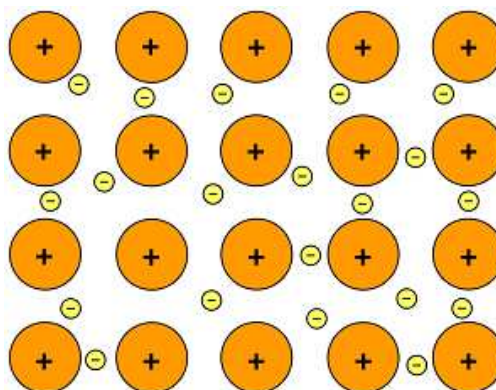

The **more free electrons** and more protons the ions possess, the **stronger a metal** becomes.

Conducting heat and electricity

Because these "free" (or **delocalised**) electrons are free to move about the metallic structure, this allows metals to conduct electricity and conduct heat.

The more free electrons a metal has, the better it is at conducting both electricity and heat.

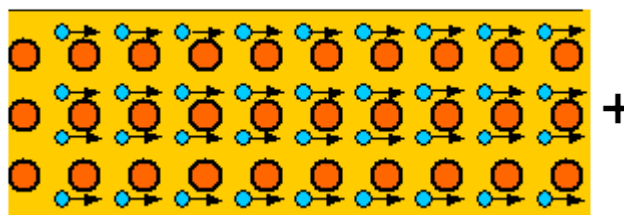

Malleable and ductile

Metals are also malleable (hit into shape) and ductile (drawn into wires) because the free electrons allow the metal atoms to slide over each other.

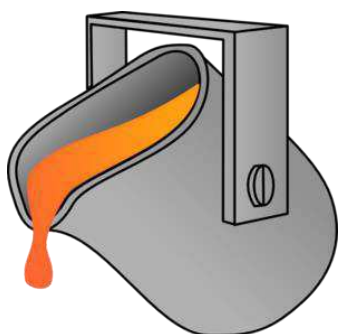

Melting and Boiling points

Metallic bonds are strong and a **lot of energy** is needed to break them. This is why metals have high melting points and boiling points.

Higher tier

As the number of free electrons increase, i.e. move across the periodic table from left to right, so too does the melting and boiling points. This is because of the increased attraction between the positive ions and the free electrons.

Think about the melting points of sodium, and other group 1 metals, compared to iron.

Sodium forms Na^+ and Iron (III) forms Fe^{3+} .

Examples of ionic bonding:

1. Sodium chloride (NaCl)

Group 1 metal with a group 7 non-metal (halide)

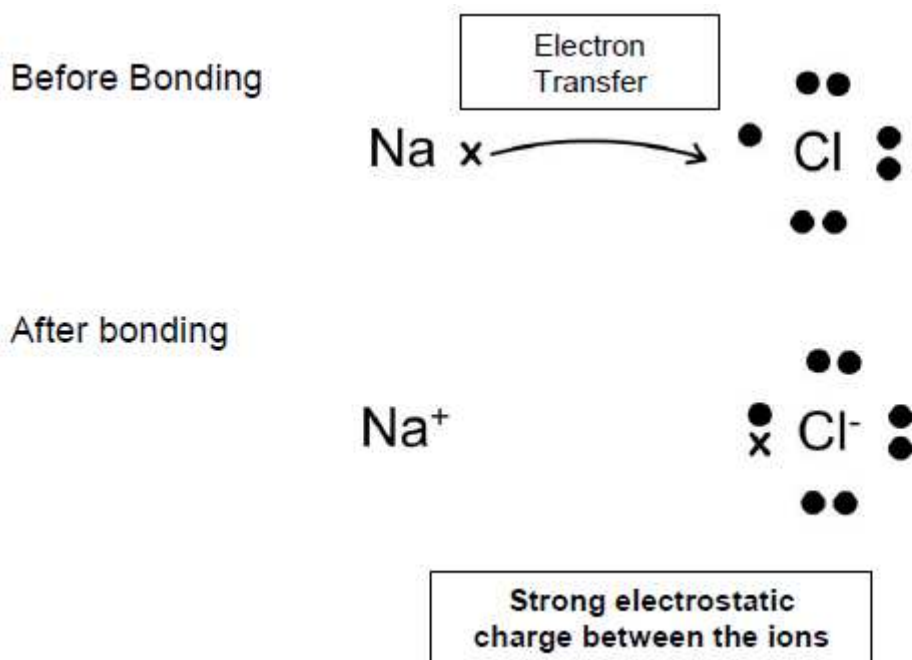

2. Magnesium oxide (MgO)

Group 2 metal with a group 6 non-metal

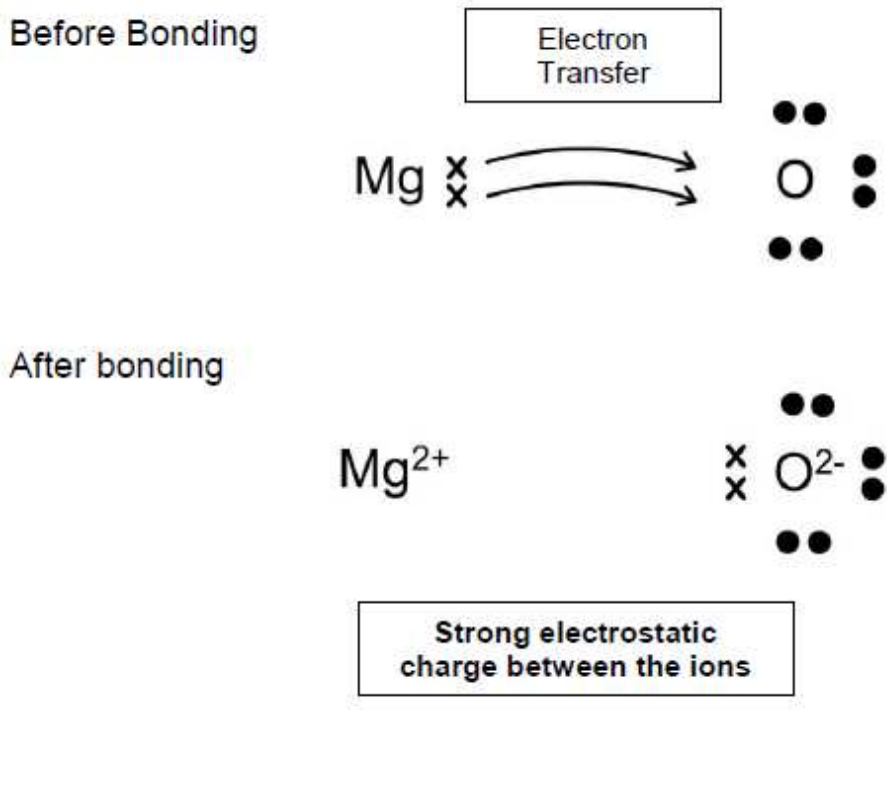

3. Lithium Oxide (Li₂O)

Group 1 metal with a group 6 non-metal

Before Bonding

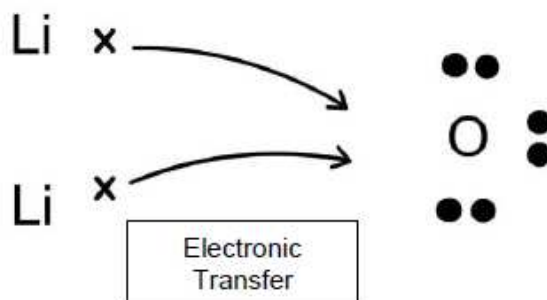

After bonding

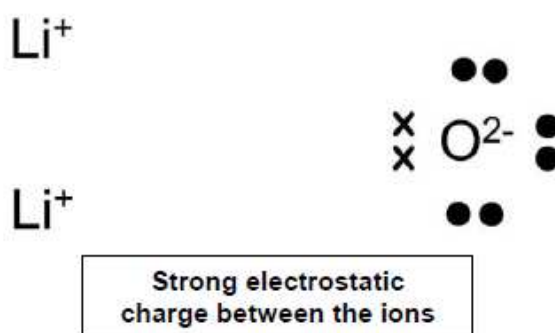

4. Magnesium Chloride (MgCl₂)

Group 2 metal with a group 7 non-metal (halide)

Before Bonding

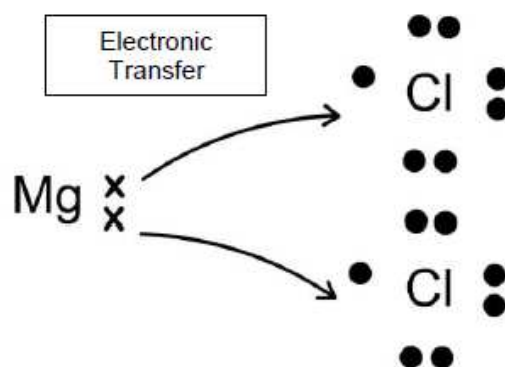

After bonding

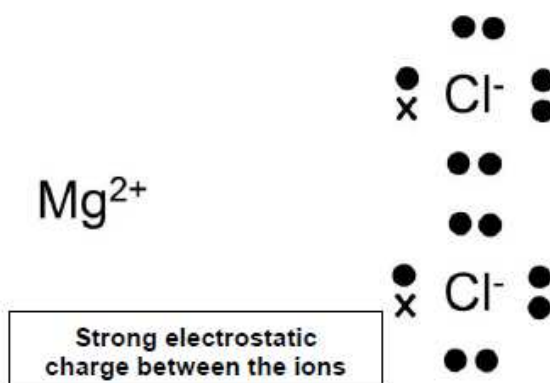

Covalent bonding

When hydrogen gas (H_2) forms, electrons are shared between two atoms to form a molecule. These molecules are **neutral** (no charge).



Electrons share to form a full outer shell

Examples of covalent bonding:

1. Chlorine (Cl_2)

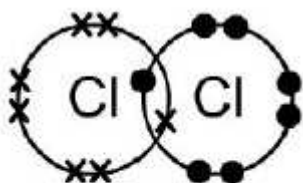

Electrons share to form a full outer shell

2. Water (H_2O)

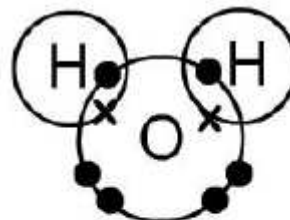

Electrons share to form a full outer shell

3. Ammonia (NH_3)

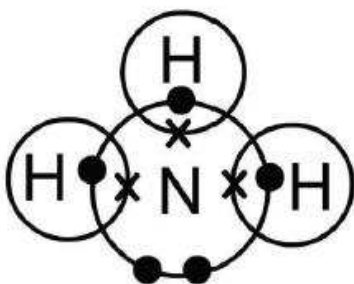

4. Methane (CH_4)

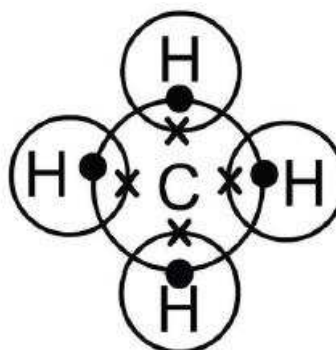

Higher tier

Molecules that contain double bonds

Oxygen (O_2)

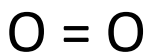

Ethene (C_2H_4)

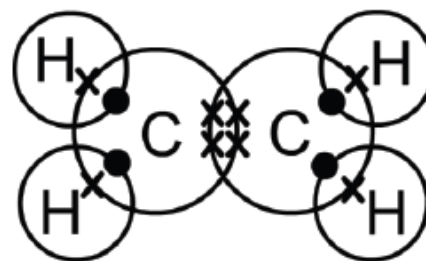

Carbon dioxide (CO_2)

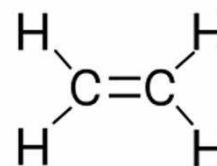

Simple and Giant structures

1. Giant ionic structures

There are many ionic bonds in an ionic compound such as sodium chloride, arranged in **giant lattice structures**. Ionic compounds have **high melting and boiling points** because of the strength of the **electrostatic forces** of attraction between oppositely-charged ions.

The oppositely-charged ions are arranged in a regular way to form a giant ionic lattice. It is a 'lattice' because the arrangement is a regular one and 'giant' because the arrangement is repeated many times with large numbers of ions.

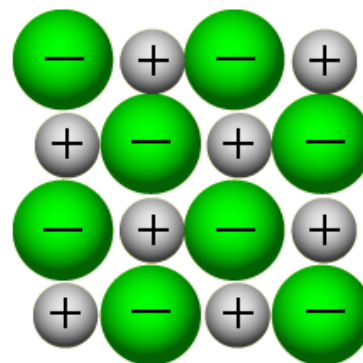

Ionic compounds often form **crystals** as a result.

The number of ions in an ionic compound is such that the **overall charge** of a sample of the compound is **zero**.

For an ionic substance to **conduct electricity**, its ions must be free to move so that they can carry charge from place to place. Ions are free to move when an ionic compound is a **molten liquid** or **in solution** (i.e. dissolved in water or another solvent) but **not when it is solid**.

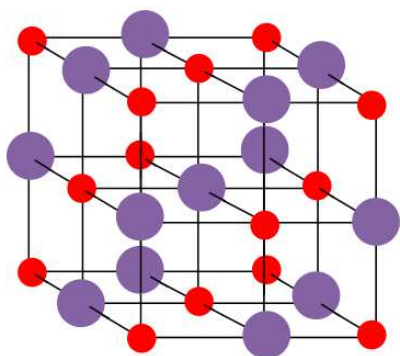

Higher tier

The melting point of sodium chloride is lower than that of magnesium oxide because it has weaker ionic bonds, which need less heat energy to break/overcome.

This is for two reasons:

1. The Na^+ and Cl^- ions in sodium chloride have fewer charges than the Mg^{2+} and O^{2-} ions in magnesium oxide.
2. Na^+ ions are larger than Mg^{2+} and cannot get as close to the negatively charged ions.

2. Simple molecular structures

Simple molecules consist of a small number of atoms joined by **covalent bonds**. For example, water and carbon dioxide exist as simple molecules.

The covalent bonds binding the atoms together are very strong but there are only **very weak forces** holding the molecules to each other (the **intermolecular forces**).

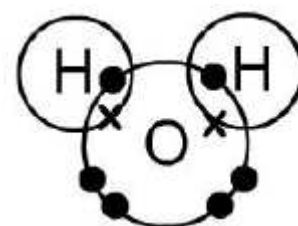

Therefore, only a **low temperature** is needed to separate the molecules when they're melted or boiled.

This means that compounds that have **simple molecular structures** have **low boiling and melting points**. There are no free electrons to carry an electrical current, so simple molecular structures **do not conduct electricity**.

3. Giant covalent structures

They contain a lot of non-metal atoms, each joined to adjacent atoms by **covalent bonds**. Their atoms are arranged into giant **lattices**, which are strong structures because of the many bonds involved.

Substances with giant covalent structures have **very high melting points**, because a lot of strong covalent bonds must be broken.

Examples of giant covalent structures:

Diamond

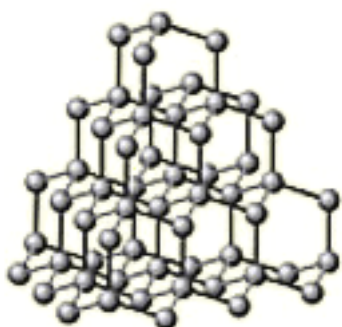

Diamond is a form of carbon in which each carbon atom is joined to four other carbon atoms, forming a giant covalent structure. As a result, diamond is very hard and has a high melting point, over 3500°C.

It **does not conduct electricity**.

Appearance - Transparent/crystalline.

Uses - Gemstones, Glass cutting, Drill bits.

Graphite

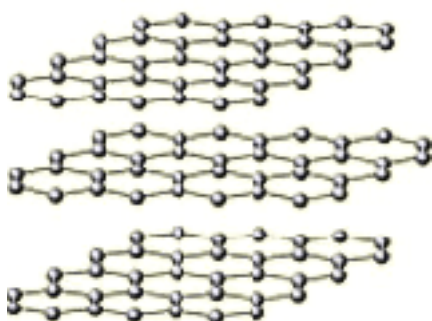

Graphite is a form of carbon in which the carbon atoms form layers. Each carbon atom in a layer is joined to only three other carbon atoms.

The fourth electron of each carbon atom becomes delocalised between the layers. This is why graphite **conducts electricity**.

The layers can slide over each other because there are no covalent bonds between them. This makes graphite much softer than diamond. It is used in pencils and as a *lubricant*.

Silica

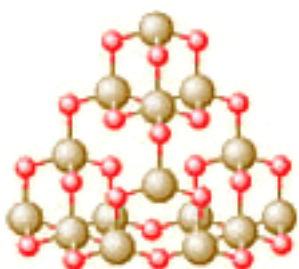

Silica, which is found in sand, has a similar structure to diamond. It is also hard and has a high melting point.

However,
it contains silicon and oxygen atoms instead of carbon atoms.

Carbon

Carbon exists as graphite and diamond, but it can also form...

Fullerenes

These are cages and tubes with different number of carbon atoms.

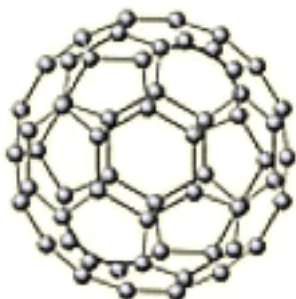

Buckminsterfullerene is one type of fullerene. Its molecules are spherical and contain 60 carbon atoms.

Fullerenes may be used for *drug delivery systems* in the body, in *lubricants* and as *catalysts*.

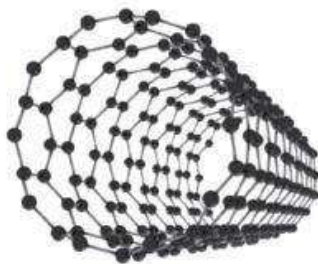

The tube fullerenes are called **nanotubes**. They are useful in reinforcing structures where lightness and strength are needed.

They conduct electricity / used in semi-conductors.

They have a very small diameter which is about 10,000 times less than a human hair.

They are extremely strong. Very low density.
They are proposed to be used in **small electronic circuits**.

Carbon nano-tubes are made from single layers from a graphite structure, known as **graphene layers**, rolled into tubes.

It should be noted that carbon nano-tubes have a **much smaller scale structure than carbon fibres** and are not what is used in the manufacture of bikes and tennis rackets.

Graphene has been shown to be the **strongest material** ever tested and also the **best electrical conductor** but although claims have been made that it will transform technology in the future, there are as yet no commercially available 'graphene products'.

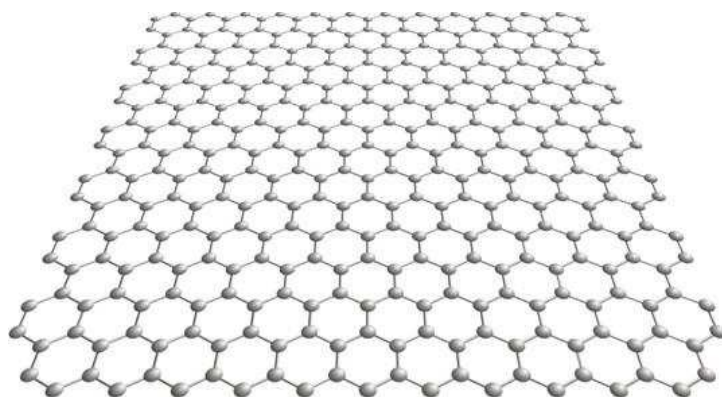

Individual atoms **do not** have the same properties as bulk materials.

This is demonstrated by diamond, graphite, fullerenes, carbon nano-tubes and graphene having different properties despite all containing **only carbon atoms**.

Smart materials

Smart materials have properties that **react to changes in their environment**. This means that one of their properties can be changed by an external condition, such as **temperature, light, pressure, pH** or **electricity**. This change is **reversible** and can be repeated many times.

Smart materials are:

1. **Reversible**
2. **React to environment**

There are a wide range of different smart materials. Each offer different properties that can be changed.

1. Shape-memory alloys / polymers

For most materials, if they are bent out of shape, they stay that way. However, if a part made from a shape-memory alloy is bent out of shape, when it is heated above a certain temperature it will return to its original shape.

This property makes it useful for making spectacle frames - they return to their original shape if they are put in hot water after bending them.

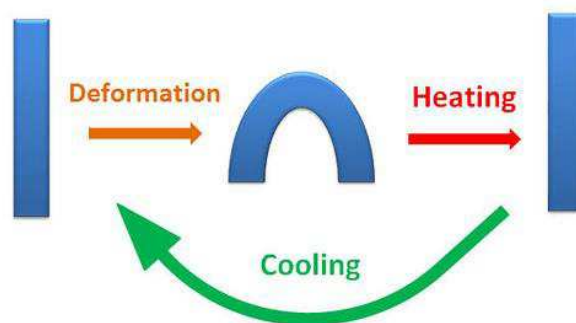

Shape memory alloys are used as triggers to start the sprinklers in fire alarm systems, controllers for hot water valves in showers or coffee machines and for spectacle frames.

2. Colour-change materials

Thermochromic materials change colour as the **temperature** changes. These are used on contact thermometers made from plastic strips. They are also used as food packaging materials that show you when the product they contain is cooked to the right temperature.

Photochromic materials change colour according to different **lighting** conditions or changing **light intensity**. They are used for security markers that can only be seen in ultraviolet light.



3. Polymer gels e.g. hydrogels

Hydrogels are used to make soft contact lenses, **nappies**, wound dressings and drug delivery systems.

They are used because they can absorb/expel water and swell/shrink (up to 1000 times their volume) due to changes in pH, temperature, salt concentration, etc.

Others:

Electroluminescent materials

Electroluminescent materials give out light when an electric current is applied to them. Among many possible applications are safety signs and clothing for use at night.

Nano-materials

Nanoparticles range in size from 100 nm to 1 nm and are far too small to see with a microscope. They have remarkable properties that are **different from the same substance in bulk**. They are already being used in consumer products but there are some **uncertainties about their safety**.

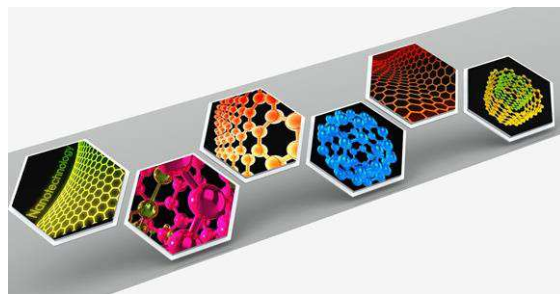

Properties and uses of nanoparticles

Nanoparticles have a very large surface area compared with their volume, so they are often able to react very quickly. This makes them useful as catalysts to speed up reactions. They can, for example, be used in self-cleaning ovens and windows.

Nanoparticles also have different properties to the same substance in normal-sized pieces.

For example, **titanium dioxide** is a white solid used in house paint and certain sweet-coated chocolates. Titanium dioxide nanoparticles are so small that they do not reflect visible light, so cannot be seen. They are used in **sun screens** to block harmful ultraviolet light without appearing white on the skin.

Self-cleaning glass is coated with nano-scale titanium dioxide particles. These catalyse the breakdown of dirt in the presence of UV light and also cause water to spread out in a thin film, rather than forming droplets on the surface. The combined effort of sunshine and rainwater cleans the windows!

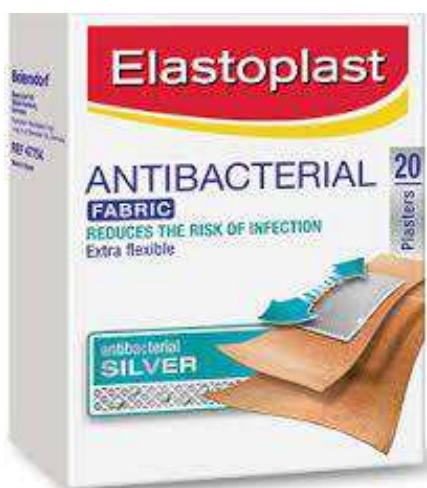

Nano-sized **silver particles** are antibacterial, antiviral and antifungal and that they are used in **plasters, antiseptic sprays**, refrigerator linings, socks, **deodorant sprays**.

In addition to new cosmetics such as sun screens and deodorants, nanoscience may lead to the development of:

- New catalysts
- New coatings
- New computers
- Stronger and lighter building materials
- Sensors that detect individual substances in tiny amounts

Higher tier

Nanomaterials currently used have been tested to ensure that they cause no damage to individuals or the environment, but that their **long-term effects** are as yet unknown. Some people have expressed concern that nano-scale silver (deodorants) and titanium dioxide (sun screens) are applied to the skin and can therefore be easily absorbed into the body. While it has been shown that these uses are safe in the short term, there is no certainty that exposure over many years will not result in problems.

Topic 2 - ACIDS, BASES AND SALTS

Acids and alkalis are some of the most widely used chemicals both in industry and our homes.

Common acids and alkalis

Most people think **acids** are dangerous, and **some** are. Concentrated **sulfuric acid** is **very corrosive**, and must be handled with care. But other acids are common chemicals that we use every day. **Acetic acid** - also called **ethanoic acid** - is present in vinegar. **Citric acid** is found in fruits such as oranges and lemons. These acids are safe to eat.

It is a similar story with alkalis. A concentrated solution of the alkali **sodium hydroxide** is **very caustic**. It can be used to remove skin from bones to obtain skeletons. But **magnesium hydroxide** is such a mild alkali it can be taken as an indigestion remedy.

Acids and alkalis that are dangerous are stored in containers which have hazard warning signs to show they are **corrosive**. These chemicals need to be handled with care, with goggles and gloves worn.



Acid, Alkali or Neutral - The pH scale

It is possible to tell if a solution is **acidic** or **alkaline** by using an **indicator**. An indicator is a substance which has different colours when it is in acidic or alkaline conditions.

Litmus is probably the most well-known indicator. This is **red in acids** and **blue in alkalis**. Litmus can be used as a liquid, or as litmus paper.

Solutions of acids and alkalis can vary widely in their acidity and alkalinity. It is useful to know not just whether a solution is an acid or an alkali, but **how** acidic or how alkaline it is.

To measure acidity and alkalinity, we can use the **pH scale**.

The easiest way to do this is to use **Universal indicator**. This is a mixture of several different indicators, and can be used as a liquid or paper. It has many different colour changes. The colour of the Universal indicator shows the pH value of the solution.

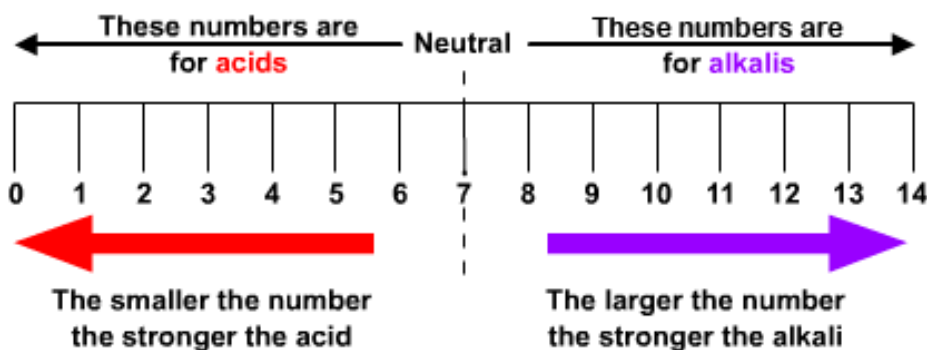
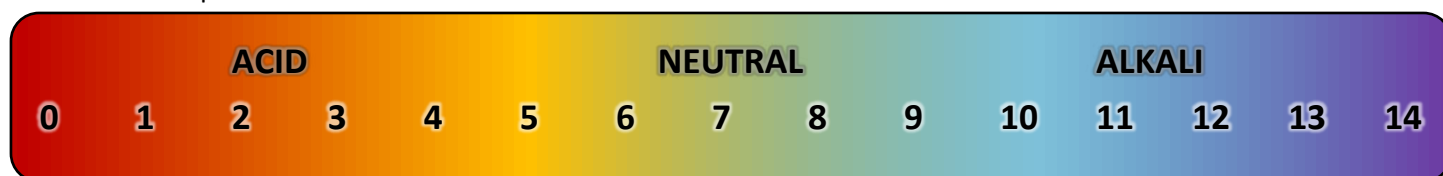

The pH scale runs from **pH 0 (strongest acid)** to **pH 14 (strongest alkali)**.

Strong acid pH 0-2 **Weak acid pH 3-5** **Neutral pH 7** **Weak alkali pH 9-11** **Strong alkali pH 12-14**

Acids, Alkalis and Bases

Acid
Release H^+ ions

Base:
Absorb H^+ ions
Alkali:
Soluble base

Metal oxides and **metal hydroxides** are known as **bases** and that an **alkali** is a **soluble base**.

e.g. MgO (magnesium oxide) is a base, but is insoluble in water.
NaOH (sodium hydroxide) is an **alkali**, as it is a base that is **soluble** in water.

Neutralisation

When an acidic compound dissolves in water it produces hydrogen ions, H^+ . These ions are responsible for the **acidity** of the solution.

When an alkaline compound dissolves in water it produces hydroxide ions, OH^- . These ions are responsible for the **alkalinity** of the solution.

Acids react with alkalis to form salts. These are called **neutralisation reactions**. In each reaction, water is also formed:



e.g. hydrochloric acid + sodium hydroxide \rightarrow sodium chloride + water

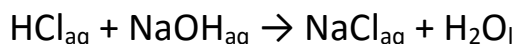

Hydrochloric acid contains **hydrogen ions** (H^+) and chloride ions (Cl^-) dissolved in water.

Sodium hydroxide solution contains sodium ions (Na^+) and **hydroxide ions** (OH^-) dissolved in water.

Higher tier

Hydrogen and hydroxide ions

The only change that does produce something different during the neutralisation is the reaction between hydrogen ions and hydroxide ions, which produces **water molecules**.

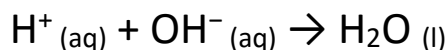

This is the ionic equation that represents the **neutralisation** reaction between any **acid** and any **alkali**.

The **name of the salt** produced in the neutralisation depends on **which acid** reacts with **which alkali**.

But the ionic equation for the neutralisation is always the same.

In the above reaction, the **salt** sodium chloride is formed when the acid and alkali are mixed together. This salt is produced as sodium ions and chloride ions in solution. There is no change to the sodium ions and chloride ions during the reaction to make sodium chloride. They were dissolved in water in the acid and in the alkali, and they are still dissolved in water as the salt.

Reactions of acids

Acids **react** with metals, metal oxides, metal hydroxides and metal carbonates. During each of these reactions a salt is made.

1. Acid with metal

Acids will react with reactive **metals**, such as magnesium and zinc, to make a **salt** and **hydrogen**. This reaction is **exothermic** – releases heat.

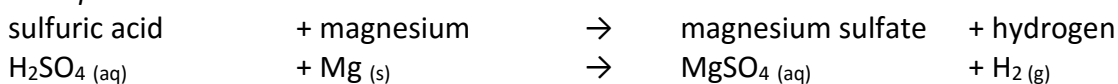
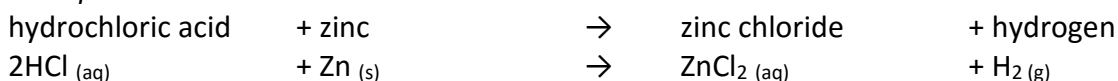
*Example 1:**Example 2:***Hydrogen test**

The hydrogen causes bubbling during the reaction. It can be detected using a **lighted splint**, which causes the gas to burn with a **squeaky pop**.

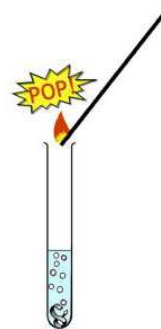

2. Acid with base

a. Acid with an insoluble base (metal oxide)

Acids react with **metal oxides**, such as magnesium oxide, to produce a **salt** and **water**. This reaction is **exothermic**.

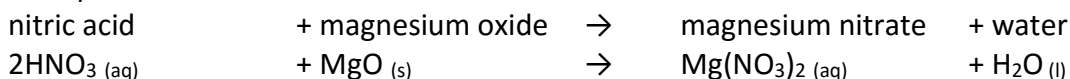
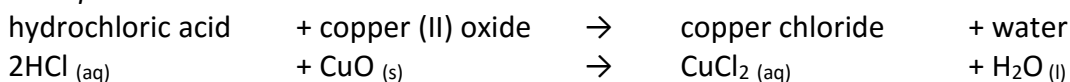
*Example 1:**Example 2:*

b. Acid with an alkali (metal hydroxide)

Acids react with **metal hydroxides**, such as sodium hydroxide, to produce a **salt** and **water**. This reaction is **exothermic**.

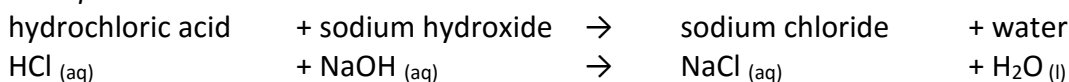
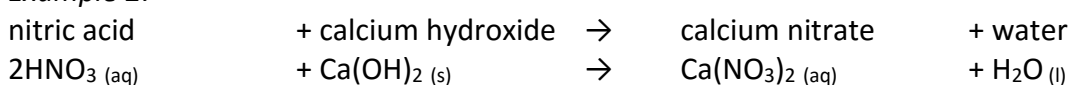
*Example 1:**Example 2:**c. Acid with a carbonate (metal carbonate)*

Acids react with **metal carbonates**, such as copper carbonate, to produce a **salt**, **water** and **carbon dioxide**. This reaction is **exothermic** and **effervesces (fizzes)**.

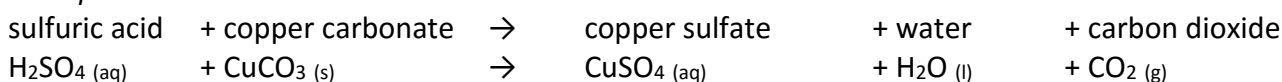
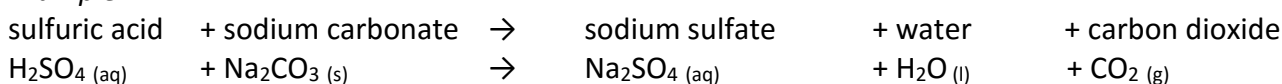
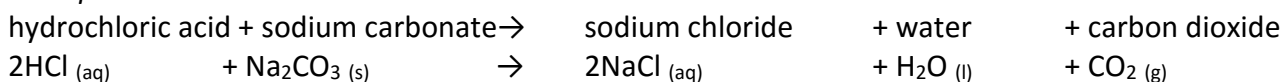
*Example 1:**Example 2:**Example 3:***Carbonate test**

When acid reacts with a carbonate **fizzing** is observed. Bubbles are seen, as CO_2 is a gas.

Carbon dioxide test

The carbon dioxide (CO_2) causes **bubbling/fizzing** during the reaction. It can be detected using **limewater**, which turns a **milky white** when **carbon dioxide** is bubbled through it.

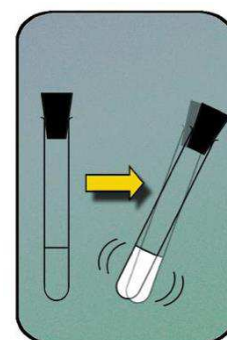

Summary of reactions of acids

Naming salts is an important aspect of acid reactions. You need to be able to name the salts formed from the acid.

Acid

Salt formed

1. Hydrochloric acid → metal chloride
2. Sulfuric acid → metal sulfate
3. Nitric acid → metal nitrate

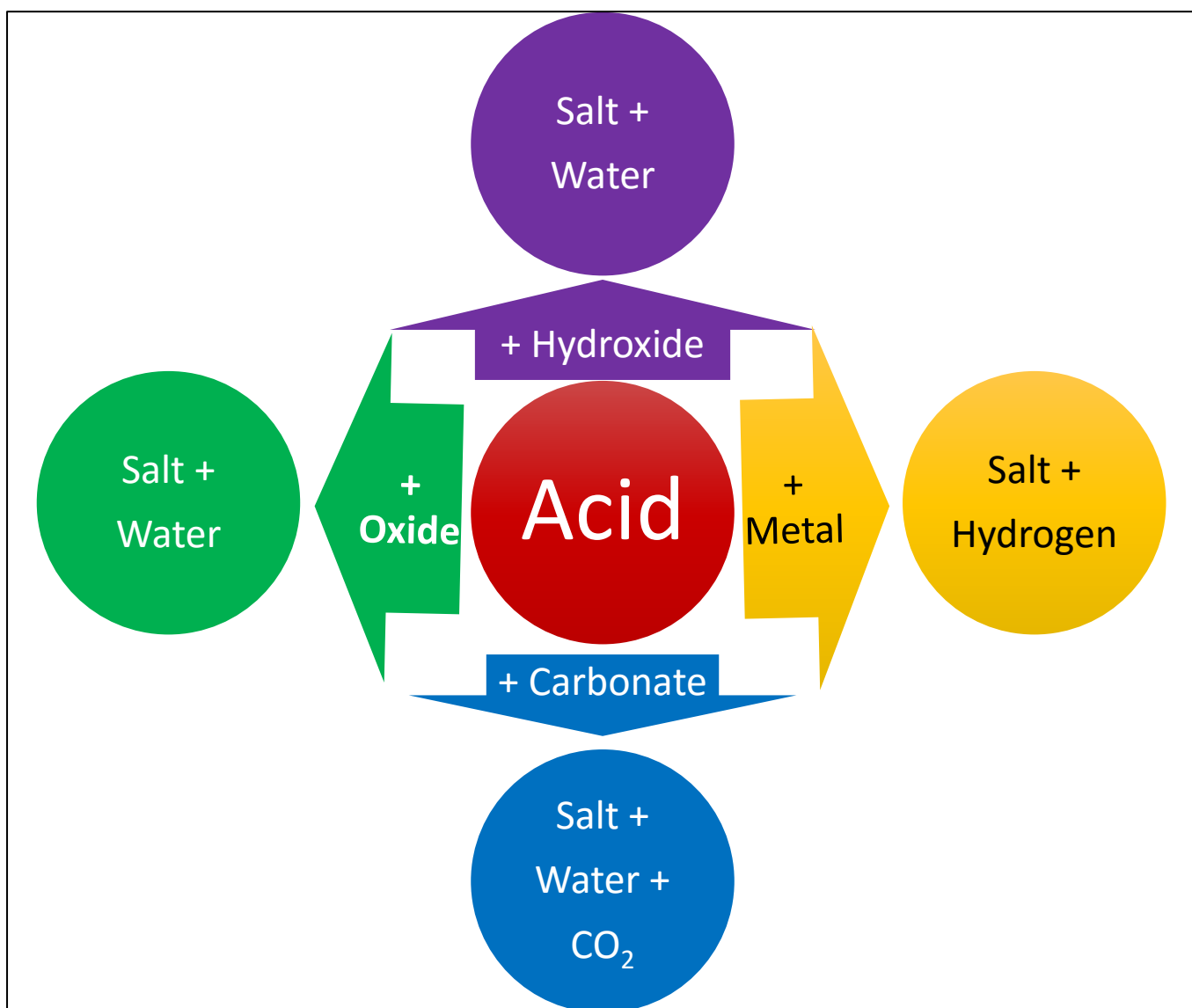

Exothermic reactions

All neutralisation reactions are **exothermic** – heat is released. This change can be measured by using a **thermometer**.

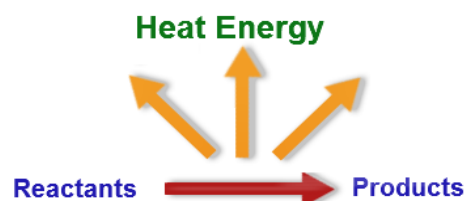

Sulfate test

Another test that you need to know is the **sulfate test**. This involves adding **barium chloride** solution to the test solution.

If there are **sulfate ions (SO_4^{2-})** present → **white** precipitate forms

Ionic equation:

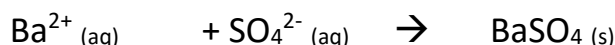

Example:

If sodium sulfate solution is tested:

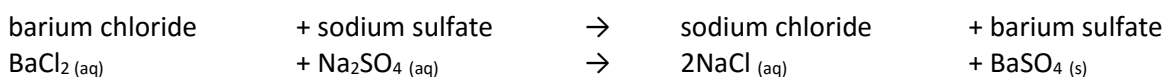

Tests for gases

Often, during chemical reactions, a gas will be given off, we need to be able to identify these gases.

Oxygen

Oxygen will re-light a glowing splint

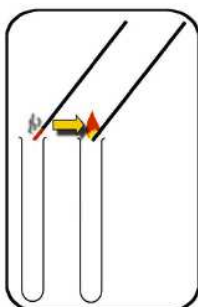

Hydrogen

Can be detected using a **lighted splint**, which causes the gas to burn with a **squeaky pop**.

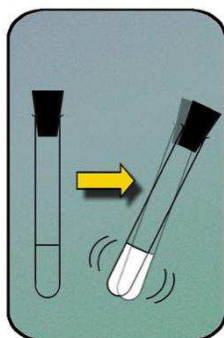
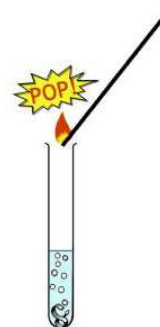

Carbon dioxide

Can be detected using **limewater**, which turns a **milky white** when **carbon dioxide** is bubbled through it.

Preparation of salt crystals

Using the neutralisation reactions of insoluble bases and carbonates, we can form salt crystals. You need to remember this method.

Example method – copper oxide and sulphuric acid to form copper sulfate crystals

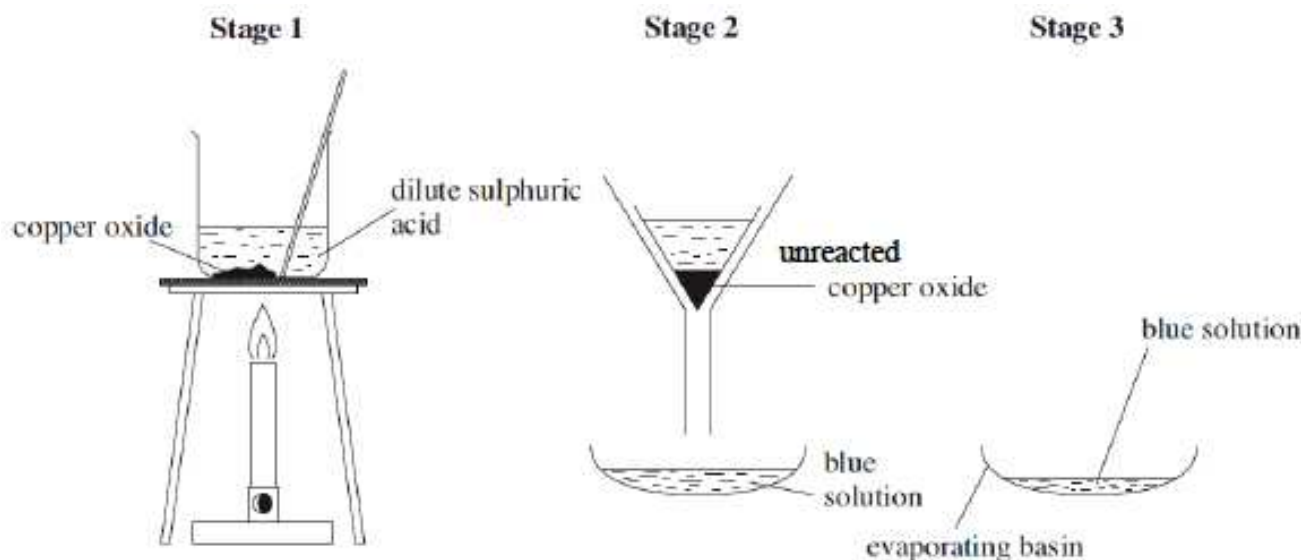

Stage 1:

Excess base (copper oxide) is added to the dilute acid to make sure all the acid has been reacted and used up. Heating and stirring will assist the process

Stage 2:

The excess (unreacted) base is removed by the process of **filtration**, using a filter funnel and filter paper

Stage 3:

Salt is obtained by **evaporation** – water evaporates and crystals of salt left behind.

Large crystals - water can be evaporated slowly near a window over a period of a few days.

Small crystals - with additional heating to evaporate until about 1/3 of the solution remains, and the rest should be left to cool and evaporate naturally.

Obtaining salt crystals from the **metal carbonate** and **acid** reaction

The only difference in the method is stage 1 – excess metal carbonate is used – to make sure all the acid has been used up.

Obtaining salt crystals from the **metal** and **acid** reaction

The only difference in the method is stage 1 – excess metal is used – to make sure all the acid has been used up.

Titration

Another important method that is used in chemistry is titration, this involves using a **burette** to slowly add a solution to another.

Carrying out a titration

The **concentration** of an acid or alkali can be calculated by carrying out an experiment called a titration. You should be able to identify the apparatus needed to carry out a simple acid-alkali titration, and to describe how it is done.

Materials

The apparatus needed includes a:

- **pipette** to accurately measure a certain volume of acid or alkali
- **pipette filler** to use the pipette safely
- **conical flask** to contain the liquid from the pipette
- **burette** to add small, measured volumes of one reactant to the other reactant in the conical flask

Example method

1. Use the pipette and pipette filler to add 25 cm³ of alkali to a clean conical flask.
2. Add a few drops of indicator and put the conical flask on a white tile (so you can see the colour of the indicator more easily).
3. Fill the burette with acid and note the starting volume.
4. Slowly add the acid from the burette to the alkali in the conical flask, swirling to mix.
5. Stop adding the acid when the end-point is reached (the appropriate colour change in the indicator happens). Note the final volume reading.
6. Repeat steps 1 to 5 until you get consistent readings

The same method works for adding an alkali to an acid - just swap around the liquids that go into the conical flask and burette.

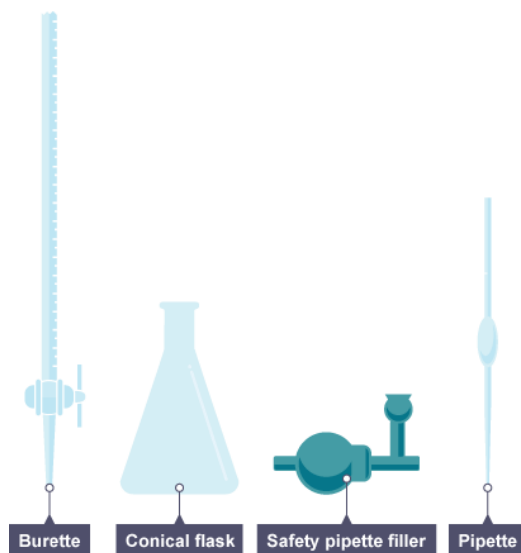

The titre

The **difference** between the reading at the **start** and the **final** reading gives the volume of acid (or alkali) added. This volume is called the **titre**.

For example, if the reading at the start is 1.0 cm³ and the final reading is 26.5 cm³, then the titre is 25.5 cm³ (26.5 – 1.0). Note that the titre will depend upon the volume of liquid in the conical flask, and the concentrations of the acid and alkali used.

It is important to **repeat the titration several times** to check that your titre value is consistent so that your calculations are **reliable**.

Indicator

If universal indicator is used, the colour changes gradually through a range of colours. On the other hand, a single indicator like litmus or phenolphthalein gives a **sharp end-point** where the **colour changes suddenly**.

pH curves

The change in pH can be estimated using universal indicator, or measured more accurately using a **pH meter**, when an acid and an alkali are mixed.

A graph of pH (on the vertical axis) against total volume of acid or alkali added (on the horizontal axis) is called a **pH curve**. You need to be able to interpret a simple pH curve. If you are taking the Higher Tier paper you may have to sketch a pH curve.

1. Adding acid to alkali

The pH curve below shows what happens to the pH when a **strong acid** (such as hydrochloric acid) is added to 25 cm³ of a **strong alkali** (such as sodium hydroxide). The acid and the alkali started off at the same concentration.

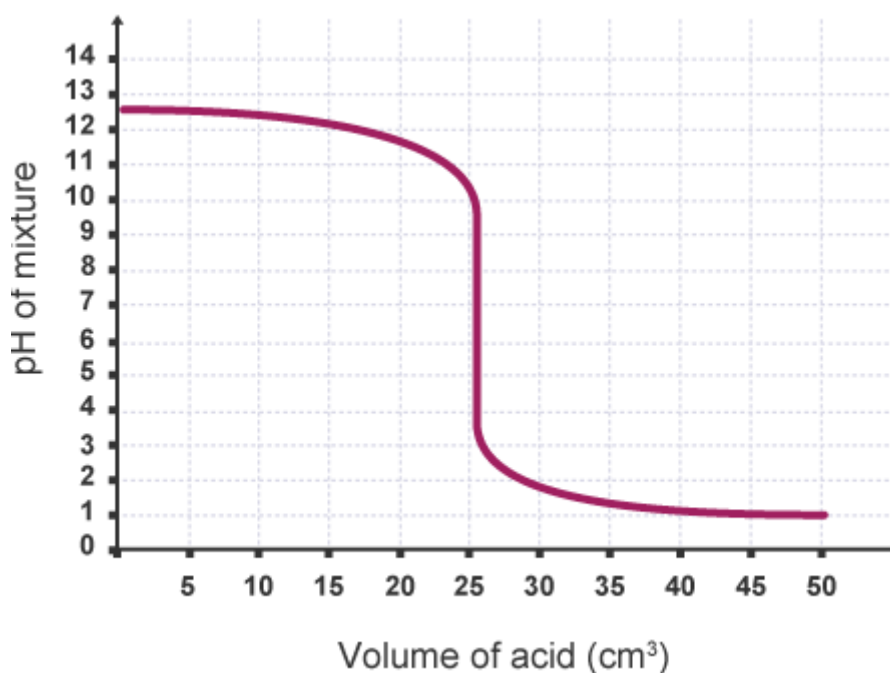

Describing and explaining the graph

Graph shows how pH varies as increasing quantities of acid are added to an alkali. It starts at around 12.5 and decreases slowly until the volume of acid reaches 25 cm³, at which point pH falls sharply from 10 to 3 and then decreases slowly to 1, when volume of acid is 50 cm³.

Note that the pH falls:

- slowly at first as acid is added to the alkali
- rapidly at the **end-point** (the point where the alkali is completely neutralised)
- slowly again once excess acid is being added

In this example, 25 cm³ of acid was needed to neutralise the alkali. If the acid had been more concentrated than the alkali, the volume needed would have been less than 25 cm³. The mixture was pH 12 at 20 cm³ and at pH 2 at 30 cm³. It was pH 7 at the **end-point**.

2. Adding alkali to acid

The pH curve below shows what happens to the pH when a **strong alkali** is added to 25 cm³ of a **strong acid**. As before, they both started off at the same concentration.

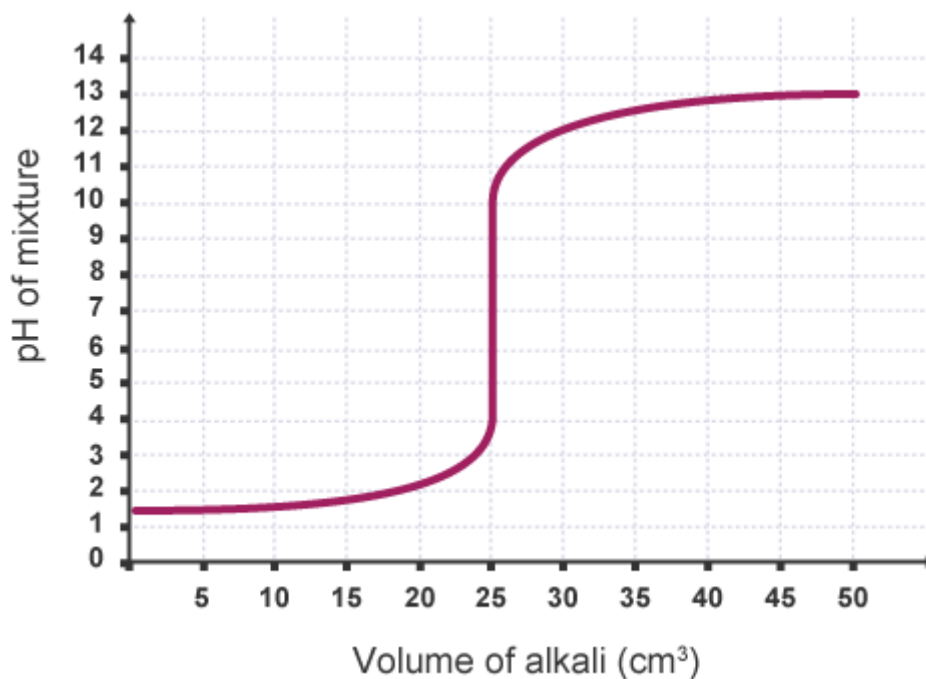

Describing and explaining the graph

Graph shows how pH varies as increasing quantities of alkali are added to an acid. It starts at around 1 and increases slowly until the volume of alkali reaches 25 cm³, at which point pH rises sharply from 3 to 10 and then increases slowly to 12.5, when volume of alkali is 50 cm³.

Note that the pH rises:

- slowly at first as alkali is added to the acid
- rapidly at the **end-point** (the point where the acid is completely neutralised)
- slowly again once excess alkali is being added

In this example, 25 cm³ of alkali was needed to neutralise the acid. If the acid had been more concentrated than the alkali, the volume needed would have been more than 25 cm³.

Preparing a salt crystals using titration then evaporation

You should know the method used to prepare crystals of soluble salts from the reaction of acids with alkalis.

The method is the same as the titration earlier in this topic, except:

- same fixed volume of acid/alkali in clean flask and exact volume of alkali/acid needed for neutralisation is added **but with no indicator**;

Then, we use the crystallisation method from earlier to evaporate the water to form crystals.



GCSE Chemistry ONLY

Double award - move on to **Topic 3**

Concentration

Following on from Unit 1, you should be able to convert number of moles into mass. From this we can work out the concentration of a solution.

Concentration is the number of moles (or the mass) per dm³.

Equations for working out the concentration:

$$\text{Concentration (mol/dm}^3\text{)} = \frac{\text{number of moles}}{\text{volume (dm}^3\text{)}}$$

$$\text{Concentration (g/dm}^3\text{)} = \frac{\text{mass (g)}}{\text{volume (dm}^3\text{)}}$$

Higher tier

Titration calculations

You should be able to use **titration** results to calculate the **concentration** of an acid or alkali. If several runs have been carried out, any **irregular titres should be ignored** before calculating the **mean titre**.

Example 1 (1:1 mole ratio)

From an experiment, we record that 27.5 cm³ of 0.2 mol/dm³ hydrochloric acid is needed to titrate 25.0 cm³ of sodium hydroxide solution. What is the **concentration** of the sodium hydroxide solution?

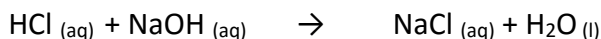

Step 1: Convert all volumes to dm³

$$\text{HCl} \quad 27.5 \text{ cm}^3 = 27.5 \div 1000 = \underline{0.0275 \text{ dm}^3}$$

$$\text{NaOH} \quad 25.0 \text{ cm}^3 = 25.0 \div 1000 = \underline{0.025 \text{ dm}^3}$$

Step 2: Calculate the number of moles of the substance where the volume and concentration are known

Rearranging the above equation gives us:

$$\text{number of moles} = \text{concentration} \times \text{volume}$$

$$\text{number of moles of hydrochloric acid} = 0.2 \times 0.0275 = \underline{0.0055 \text{ mol}} \quad (5.5 \times 10^{-3} \text{ mol})$$

Step 3: Calculate the unknown concentration

Because this reaction is a **1:1 reaction**, i.e. 1 H⁺ from the HCl reacts with 1 OH⁻ from the NaOH, we can say that **0.0055 mol of acid** will react with **0.0055 mol of alkali**

Rearranging the above equation again gives us:

$$\text{concentration} = \text{number of moles} \div \text{volume}$$

$$\text{concentration of alkali} = \text{moles} \div \text{volume} = 0.0055 \div 0.025 = \underline{0.22 \text{ mol/dm}^3}$$

Example 2 (2:1 mole ratio)

25.0 cm³ of sodium hydroxide (NaOH) solution of unknown concentration was titrated with dilute sulfuric acid (H₂SO₄) of concentration 0.050 mol/dm⁻³. 20.0 cm³ of the acid was required to neutralise the alkali. Find the concentration of the sodium hydroxide solution in mol/dm⁻³

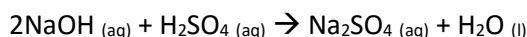

Step 1: Convert all volumes to dm³

$$\text{H}_2\text{SO}_4 \quad 20.0 \text{ cm}^3 = 20.0 \div 1000 = \underline{0.020 \text{ dm}^3}$$

$$\text{NaOH} \quad 25.0 \text{ cm}^3 = 25.0 \div 1000 = \underline{0.025 \text{ dm}^3}$$

Step 2: Calculate the number of moles of the substance where the volume and concentration are known

Rearranging the above equation gives us:

$$\text{number of moles} = \text{concentration} \times \text{volume}$$

$$\text{number of moles of hydrochloric acid} = 0.050 \times 0.020 = \underline{0.001 \text{ mol}} \quad (1 \times 10^{-3} \text{ mol})$$

Step 3: Calculate the unknown concentration

Because this reaction is a **2:1 reaction**, i.e. 2 H⁺ from the H₂SO₄ are released, so **1 H₂SO₄ : 2 NaOH**

We can say that **0.001 mol of acid** will react with **0.002 mol of alkali** (0.001 x 2)

Rearranging the above equation again gives us:

$$\text{concentration} = \text{number of moles} \div \text{volume}$$

$$\text{concentration of alkali} = \text{moles} \div \text{volume} = 0.002 \div 0.025 = \underline{0.08 \text{ mol/dm}^3}$$

Try these:

1. A student reacted 25 cm³ of 1 mol/dm⁻³ HCl with 25 cm³ of 1 mol/dm⁻³ NaOH, is the solution alkali, acidic or neutral?
2. A student reacted 25 cm³ of acid (HCl) with 20 cm³ alkali (NaOH) to make a neutral solution, which had the highest concentration, the acid or the alkali?
3. A student reacted 10 cm³ of acid (HCl) with 40 cm³ alkali (NaOH) to make a neutral solution, which had the weakest concentration, the acid or the alkali?

Strong and weak acids

Acid solutions contain **hydrogen ions**. The higher the **concentration of hydrogen ions**, the **lower the pH**. Hydrochloric acid is a **strong acid** and **ethanoic acid** is a **weak acid**.

Strong acids are **fully ionised** but weak acids are only **partly ionised** in solution. At the same concentration, strong acids have a higher concentration of hydrogen ions than weak acids.

Acids ionise in water to produce hydrogen ions, H⁺.

Strong acids fully ionise. For example:

- hydrochloric acid: $\text{HCl} \rightarrow \text{H}^+ + \text{Cl}^-$
- nitric acid: $\text{HNO}_3 \rightarrow \text{H}^+ + \text{NO}_3^-$
- sulfuric acid: $\text{H}_2\text{SO}_4 \rightarrow 2\text{H}^+ + \text{SO}_4^{2-}$

Weak acids do not fully ionise. Instead, they form an **equilibrium** mixture. For example:

- ethanoic acid: $\text{CH}_3\text{COOH} \rightleftharpoons \text{CH}_3\text{COO}^- + \text{H}^+$

At the same concentration, strong acids have lower pH than weak acids.

pH and hydrogen ion concentration

The **pH** of a solution is related to its **concentration of hydrogen ions** - the higher the concentration of hydrogen ions H⁺ the lower the pH.

At the same concentration of acid, the concentration of hydrogen ions will be higher in a strong acid than in a weak acid. This is why the pH of a strong acid like hydrochloric acid will be lower than the pH of a weak acid like ethanoic acid.

Acid strength vs concentration

The **strength of an acid** is a measure of the degree of its **ionisation** - strong acids are fully ionised but weak acids are only partly ionised. Remember: the opposite of strong is weak.

The **concentration of an acid** is a measure of the **number of moles of acid in 1 dm³ of acid solution**. For example, 2 mol/dm³ hydrochloric acid is twice as concentrated as 1 mol/dm³ hydrochloric acid or 1 mol/dm³ ethanoic acid. Remember: the opposite of concentrated is dilute.

Reactions of acids - further

Both strong acids and weak acids will react with magnesium or with calcium carbonate. However, the **rate of reaction** will be different – a **strong acid** produces a **faster reaction** than a weak acid at the same concentration.

Metal and acid

Magnesium reacts with acids to produce a magnesium salt and hydrogen:

- magnesium + hydrochloric acid → magnesium chloride + hydrogen
- magnesium + ethanoic acid → magnesium ethanoate + hydrogen

The rate of reaction is determined by measuring the volume of hydrogen produced as the reaction goes on.

Note that **ethanoic acid** produces **ethanoate** salts.

Carbonate and acid

Calcium carbonate reacts with acids to produce a calcium salt, water and carbon dioxide:

- calcium carbonate + hydrochloric acid → calcium chloride + water + carbon dioxide
- calcium carbonate + ethanoic acid → calcium ethanoate + water + carbon dioxide

The rate of reaction is determined by measuring the volume of carbon dioxide produced as the reaction goes on.

Volume of gas produced

If the **same concentration** and **volume** of acid is used in these reactions, the **same volume of gas** is produced whether hydrochloric acid or ethanoic acid is used.

This is because both acids contain the **same amount of acid reactant** (same number of moles). The strength of the acid does not matter here.

Rate of reaction

If the **same concentration** and **volume** of acid is used in these reactions, **ethanoic acid** will react **more slowly** than hydrochloric acid. The reaction will also be **less exothermic**.

This is because the ethanoic acid will contain fewer hydrogen ions in a solution (it will have a lower concentration of hydrogen ions). There will be fewer collisions between hydrogen ions and particles of the magnesium or calcium carbonate, so the rate of reaction will be lower than for hydrochloric acid.

Precipitates

Ionic substances contain charged particles which are called **ions**. These are in fixed positions in solids, but they are free to move when they are molten or in solution. Most **precipitation** reactions involve ions from one solution reacting with ions from another solution.

In a precipitation reaction, **ions collide with one another to form an insoluble product** (one that does not dissolve in water). This is the **precipitate**.

Most precipitation reactions are very fast because there is a high chance of collisions between ions in solution. The precipitate forms as soon as two suitable solutions are mixed together

For example, copper sulfate solution is clear and blue, while sodium hydroxide solution is clear and colourless. A blue precipitate of copper hydroxide immediately forms when they are mixed.

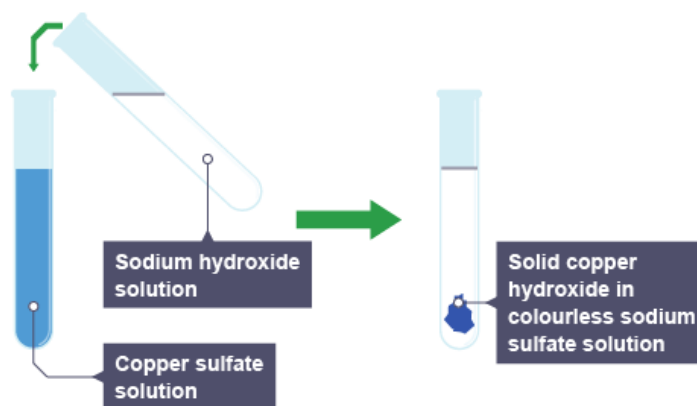

Making an insoluble compound

Insoluble compounds may be made by precipitation reactions.

Three main stages are involved:

1. Mixing the required reactant solutions.
2. Filtration to remove soluble impurities.
3. Washing and drying the residue (the insoluble compound that remains in the filter paper).

1. Mixing

All nitrates are soluble, and all sodium salts are soluble. This means that, for example, if you want to make insoluble silver bromide you can mix together silver nitrate solution and sodium bromide solution:

silver nitrate + sodium bromide \rightarrow sodium nitrate + silver bromide

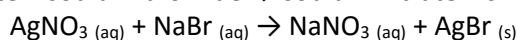

2. Filtration

The **insoluble precipitate** must be separated from the soluble impurities using **filtration**. The precipitate stays behind in the filter paper as a residue, while the soluble impurities pass through in the filtrate.

3. Washing and drying

The precipitate can be **washed** while it is still in the filter funnel. Water cannot dissolve the precipitate, but it can wash off any remaining soluble impurities. The filter paper can then be removed and opened out flat. The precipitate is then **dried in a warm oven**.

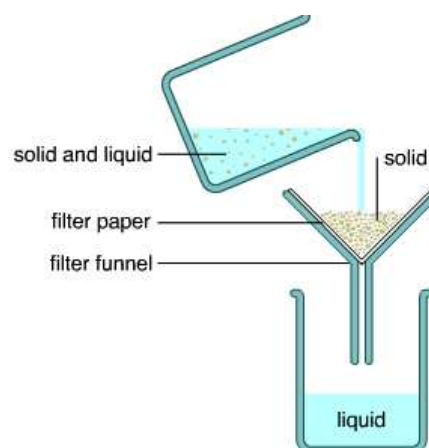

Topic 3 - METALS AND THEIR EXTRACTION

Where do metals come from?

The **Earth's crust** contains **metals** and **metal compounds** such as gold, iron oxide and aluminium oxide, but when found in the Earth these are often mixed with other substances. To be useful, the **metals have to be extracted** from whatever they are mixed with. A **metal ore** is a **rock containing a metal** (in elemental form or as a compound) in a high enough concentration to make it worthwhile extracting the metal.



Galena
(lead sulfide)

Cinnabar
(mercury sulfide)

Pyrite
(iron sulfide)

Sphalerite
(zinc sulfide)

Metal ores

The most common metal ores are oxides and sulfides. Sulfides are the oldest ores, formed in the Earth's history when there was a lot of sulfur from volcanic activity.

Oxides formed later when photosynthesis in plants released large amounts of oxygen into the atmosphere.

Metal ore deposits are a **finite resource** (there are only a certain amount of them) and **non-renewable** (once used, they are gone and will not be replaced).

Many metals are obtained today from **recycling** (smelting and refining) **scrap metals**. About half of the aluminium, copper, lead, steel and tin that is used in the UK come from recycled scrap metal.

You need to be able to identify the metals present in given ores from their **chemical formulae**.

Some common metals, their ores and chemical formulae:

| Metal | Metal Ore / Mineral | Chemical Formulae |
|-----------|---------------------|---------------------------------------|
| Aluminium | Bauxite | Al_2O_3 |
| Chromium | Chromite | FeCr_2O_4 |
| Copper | Chalcocite | Cu_2S |
| | Malachite | $\text{Cu}_2\text{CO}_3(\text{OH})_2$ |
| Iron | Hematite | Fe_2O_3 |
| Mercury | Cinnabar | HgS |
| Titanium | Rutile | TiO_2 |

Extracting metals

The method used to extract metals from the ore depends on their **reactivity**.

Thus, the method of extraction of a metal from its ore depends on the metal's position in the **reactivity series**:

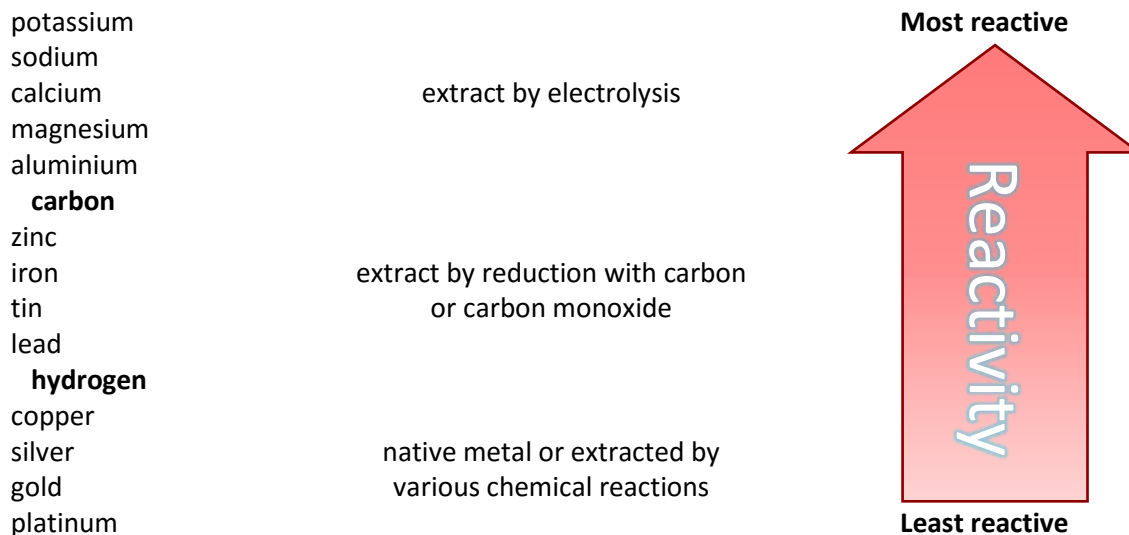

Reactive metals such as aluminium are extracted by **electrolysis**, while less-reactive metals such as iron may be extracted by **reduction** with **carbon** or carbon monoxide.

Gold and platinum occur in the Earth as **native metal**. This means that they are found as the element, not the compound, and so do not need to be **reduced**. However, chemical reactions may be needed to remove other elements/**impurities** that might contaminate the metal. Silver and copper may also be found as native metal.

Reduction

- is the process of **removing oxygen**

Oxidation

- is the process of **gaining oxygen**

Electrolysis

- is the process of **using electricity** to extract a metal

Displacement Reactions

A metal will **displace** (*take the place of*) a **less reactive metal** in a metal salt solution.

Example 1

Iron and copper sulfate

iron + copper(II) sulfate → iron sulfate + copper



If we look at the **reactivity series**, iron is **more reactive** than copper, as a result iron displaces copper.

Copper(II) sulfate is **blue**, iron sulfate is **green**. During the reaction, the blue solution loses its colour and the iron metal is seen to turn **pink-brown** as the displaced copper becomes deposited on it.

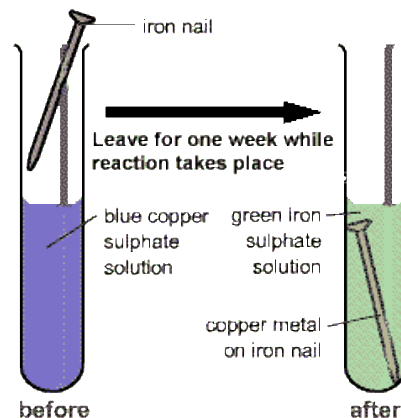

Example 2

copper and silver nitrate

copper + silver nitrate → silver + copper nitrate

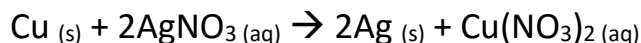

If we look at the **reactivity series**, copper is **more reactive** than silver, as a result copper displaces silver.

Example 3

iron and magnesium sulfate

If a **less reactive metal** is added to a metal salt solution there will be **no reaction** - nothing will happen!

For example, iron is **less reactive** than magnesium.

iron + magnesium sulfate → no reaction

Displacement Reactions – Oxidation / Reduction

Reduction is the **loss** of oxygen from a compound
Oxidation is the **gain** of oxygen to form a compound

During these reactions, the **more reactive** metal “takes” the oxygen off the **less reactive**.

One metal will be **reduced** and the other will be **oxidised**.

Example 1

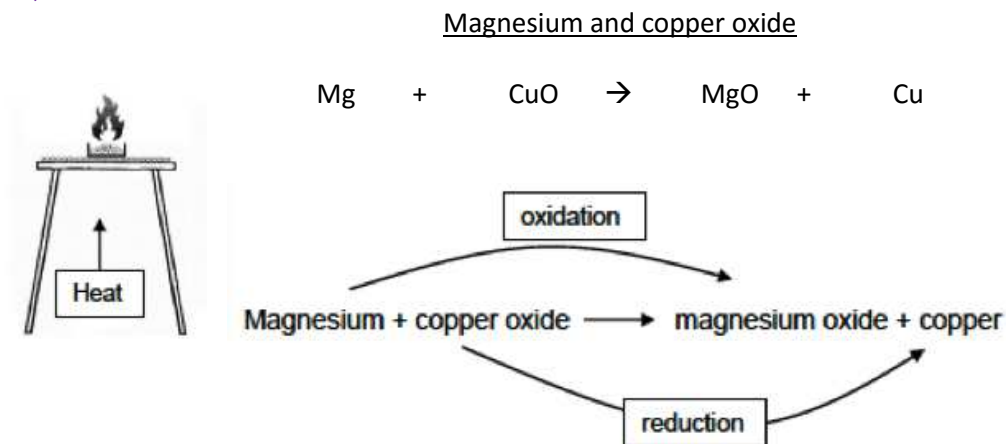

Example 2

Blast furnace reaction
Iron oxide and carbon monoxide



iron oxide + carbon monoxide → carbon dioxide + iron

In this example, the **iron oxide** is **reduced** to **iron** and the **carbon monoxide** is **oxidised** to **carbon dioxide**.

Example 3



The Thermite Reaction
Iron oxide and aluminium



In this example, the _____ is **reduced** to _____,
 and the _____ is **oxidised** to _____.

The Blast Furnace - Industrial extraction of iron

The raw materials:

Iron ore

- source of iron

Coke

- as a fuel and to produce carbon monoxide for the reduction

Limestone

- to remove impurities (slag formation when limestone breaks down and reacts with sand from the rocks)

Hot air

- provides oxygen so that coke can burn

The furnace:

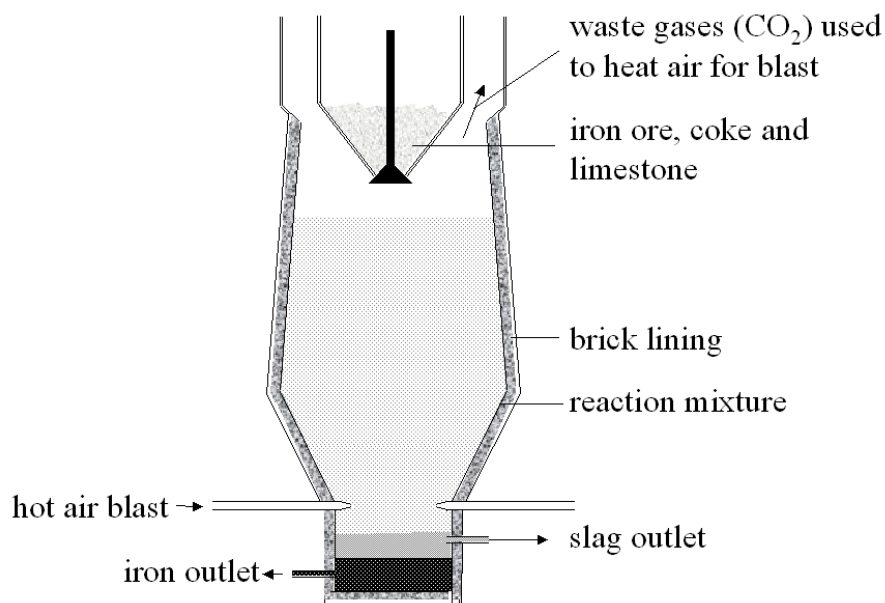

The process:

There are 4 main stages to the extraction of iron using the blast furnace:

1. **Combustion** – carbon to carbon monoxide
2. **Reduction** – iron (III) oxide to iron
3. **Decomposition** – calcium carbonate to calcium oxide
4. **Neutralisation** – calcium oxide and silicon oxide neutralisation

Stage 1 – Combustion

The coke (carbon) is burned to form carbon monoxide:

carbon + oxygen → carbon monoxide

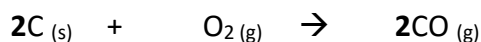
*Stage 2 – Reduction*

The carbon monoxide reduces the iron (III) oxide to iron:

Iron (III) oxide + carbon monoxide → Iron + carbon dioxide

***Stage 3 and 4 are used to remove the impurities****Stage 3 – Decomposition*

The limestone (calcium carbonate) decomposes in the heat to form calcium oxide:

calcium carbonate + **heat** → calcium oxide + carbon dioxide

*Stage 4 – Neutralisation*

The calcium oxide (stage 3) then reacts with silica (sand) impurities in the haematite, to produce **slag** - which is calcium silicate.

The calcium oxide (which is basic – *metal oxide*) from neutralises the silica (which is acidic – *non-metal oxide*):

calcium oxide + silicon dioxide (*silica*) → calcium silicate (*slag*)

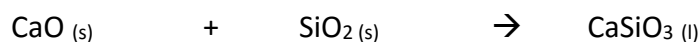

Getting the furnace up to temperature takes a lot of **time** and **costs** a lot. As a result, raw materials are constantly added and products removed - the process is **continuous**.

At the factory in Port Talbot, iron ore, limestone and coke are imported from other countries even though they are available in Wales. Using raw materials from Wales is not sustainable due to cost and the effect it could have on the environment (quarrying).

Electrolysis

Electrolysis is the process by which **ionic substances** are broken down into simpler substances using **electricity**. During electrolysis, metals and gases may form at the electrodes.

For electrolysis to work, the **ions must be free to move**. Ions are free to move when an ionic substance is **dissolved in water** or when **melted (*molten*)**. For example, if electricity is passed through molten lead (II) bromide, the lead bromide is broken down to form lead and bromine.

The **positive electrode**, called the **anode**, will attract **negatively** charged **non-metal ions**.

The non-metal ions **lose electrons** to the anode (this is called **oxidation**) and are discharged as **non-metal atoms** which often combine to form molecules.

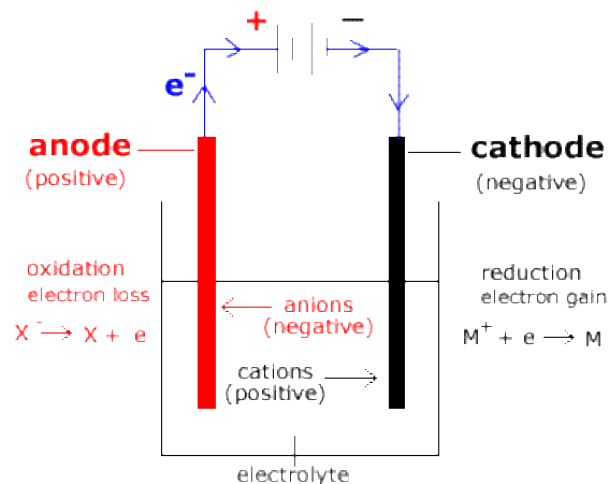

The **negative electrode**, called the **cathode**, will attract **positively** charged **metal ions**.

The metal ions **gain electrons** from the cathode (this is called **reduction**) and are discharged as **metal atoms**.

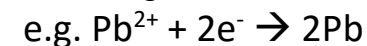

The **electrodes** are often made from **graphite (carbon)**.
The liquid that conducts electricity is called the **electrolyte**.

When *oxygen is not present*, **oxidation** and **reduction** can be defined in terms of **loss** or **gain** of electrons.

Oxidation
Loss of electrons

Reduction
Gain of electrons

Electrolysis - Industrial extraction of aluminium

Electrolysis is the method used to extract **aluminium** from **aluminium oxide**. As aluminium is a **reactive metal**, aluminium oxide is very stable, a more “powerful” method is needed to break the bonds between the aluminium and the oxygen ions.

Aluminium Extraction (Separating aluminium oxide to create aluminium)

Aluminium is the most abundant (*found in large quantities*) metal on Earth. But it is **expensive**, largely because of the amount of electricity used up in the extraction process.

Aluminium ore is called **bauxite**. The bauxite is purified to yield a white powder - aluminium oxide (**alumina**) - from which **aluminium** can be extracted.

The extraction is done by **electrolysis**. But first the aluminium oxide must be **melted** so that electricity can pass through it.

Aluminium oxide has a **very high melting point** (*over 2000°C*) so it would be expensive to melt it. Instead, it is **dissolved** in **molten cryolite** - an aluminium compound with a lower melting point than aluminium oxide. The use of cryolite **reduces** some of the **energy costs** involved in extracting aluminium.

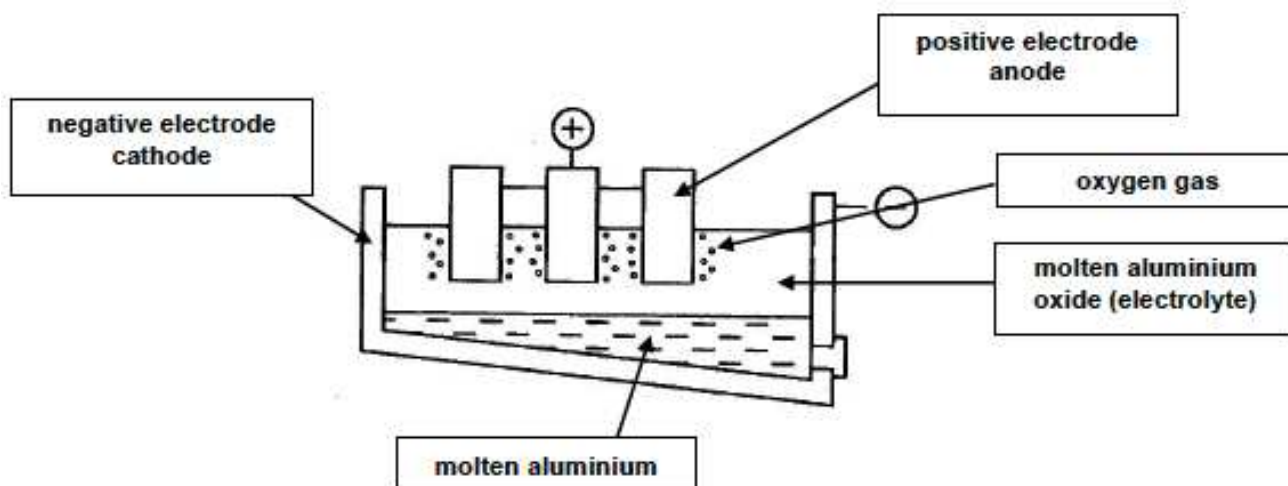

Aluminium ions (Al^{3+}) are attracted to the **negative electrode (cathode)**.

Oxygen ions (O^{2-}) are attracted to the **positive electrode (anode)**.

Cathode

aluminium ions + electrons \rightarrow aluminium atoms

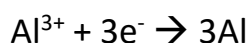

Anode

oxide ions \rightarrow oxygen molecules + electrons



You also need to be aware that the oxygen formed **reacts** with the **carbon anodes**, forming carbon dioxide gas and requiring these to be replaced frequently. This increases **more costs** to the extraction process.

Factors affecting location of industrial plants

Primary reason for siting plants near to the coast is for the importing of raw materials and not the export of products.

Other factors that affect the siting of plants include:

- A site away from built up areas;
- A town or city within commuting distance to accommodate the workforce;
- Good transport links for transporting the product to buyers;
- A direct electricity supply (a power station close by) in the case of aluminium.

Wylfa and Anglesey Aluminium

Electrolysis is an expensive process as it needs a lot electrical energy constantly. Most are located next to a power station

Aluminium is reactive so it needs an enormous amount of electricity to separate it from oxygen. Also, it is expensive as it needs heat energy to heat up the ore to 1000°C

The energy costs associated with aluminium production are **very high** and when **Wylfa Power Station** was decommissioned, **Anglesey Aluminium closed**. When it was running the plant accounted for around **10-15%** of all the electricity used in Wales. Without a power station close by, guaranteeing the supply of electricity, this became unsustainable and the plant closed.



Factories are located **near the coast** as they need to **import** the aluminium ore from abroad.

To increase the lifetime of metal ores such as aluminium oxide and iron oxide it is necessary to **recycle** metals. Recycling aluminium uses only about **5% of the energy** needed to extract it from bauxite and saves waste. Less electrical consumption means **less greenhouse gas** (CO₂) emissions. The environment is spoilt by **quarrying**.

Properties and uses of common metals

Iron and steel

Iron is an **element**. Steel is an **alloy** of iron with carbon and sometimes other elements in very small quantities. Steel is harder and stronger than iron and less likely to rust.

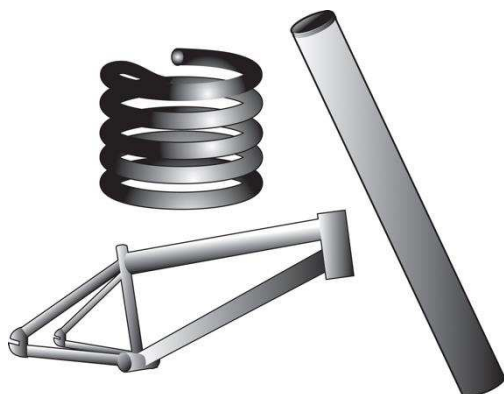

An **alloy** is a mixture of two or more elements, where at *least one element is a metal*. Most alloys are mixtures of two or more metals.

For example, brass is a mixture of copper and zinc. Steel is an alloy of iron with carbon, but other elements may also be added to change its properties.

Alloys are useful because the **properties** of the alloy are **different** from the properties of the elements they are made from.

GCSE Chemistry ONLY

Double award - move on to **Topic 4**

Identifying ions based on precipitate

Transition metal hydroxides are **insoluble** in water.

If a solution of any soluble transition metal compound is mixed with sodium hydroxide then we get a **displacement reaction**. The sodium is the more reactive metal, and displaces the transition metal from its compound.

The **transition metal hydroxide** is formed as a result. As this is insoluble it appears as a solid in the liquid – this is called a **precipitate**.

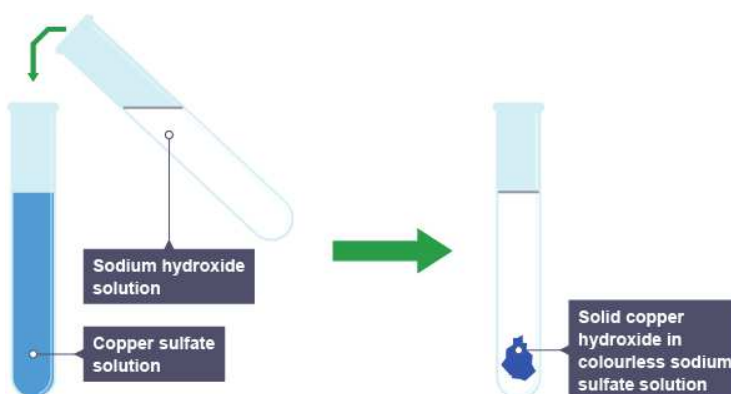
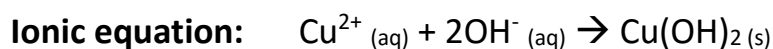
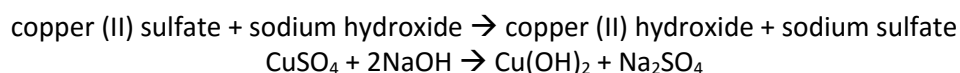
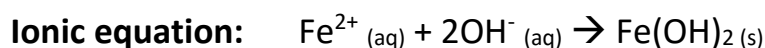
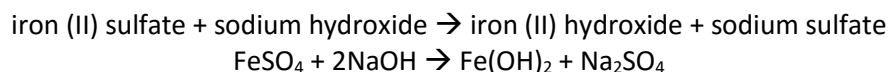
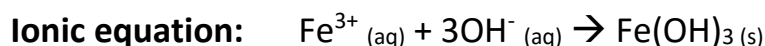
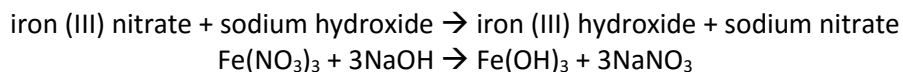
*Example 1 – Cu²⁺**Cu²⁺ forms blue compounds:*Copper (II) sulfate and sodium hydroxide*Example 2 – Fe²⁺**Fe²⁺ forms green compounds:*Iron (II) sulfate and sodium hydroxide*Example 3 – Fe³⁺**Fe³⁺ forms brown compounds:*Iron (III) nitrate and sodium hydroxide

Electrolysis – further

Electrolysis of water

Oxygen and **hydrogen** can be made from the **electrolysis** of **water**. The equipment below is used:

The Hoffmann Voltmeter:

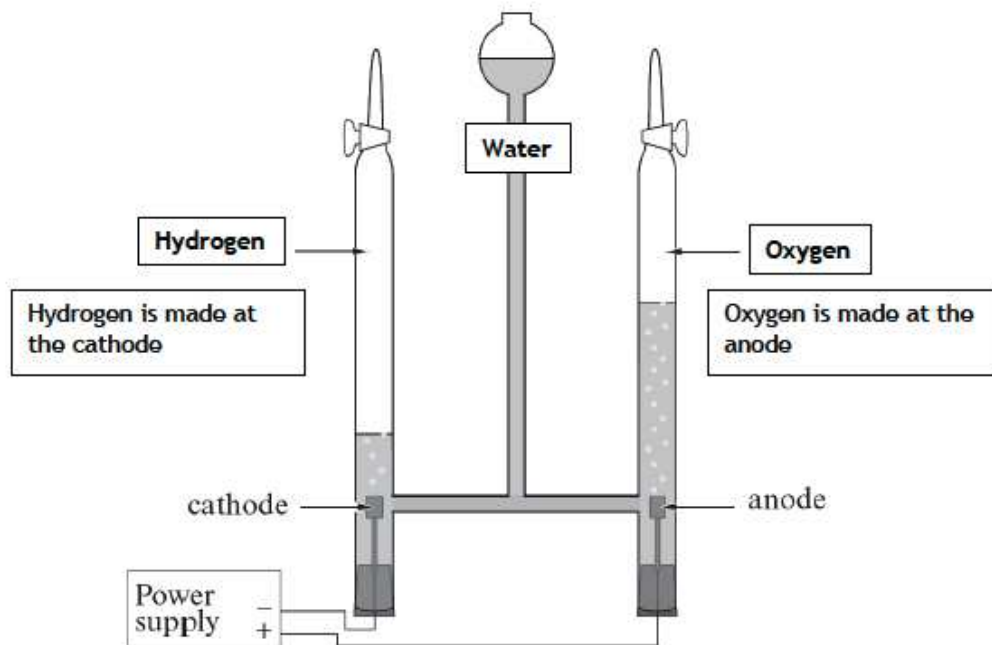

Twice the volume of hydrogen as that of oxygen is made, this is because the formula of water is **H₂O**.



Higher tier

Water breaks down into H⁺ and OH⁻ ions.

Half equations:

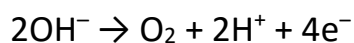

Electroplating

Electrolysis is used to electroplate objects. This is useful for **coating a cheaper metal** with a more expensive one, such as copper or silver.

How it works

- The negative electrode should be the object that is to be electroplated
- The positive electrode should be the metal that you want to coat the object with
- The electrolyte should be a solution of the coating metal, such as its metal nitrate or sulfate

Here are two examples:

Electroplating with silver

The object to be plated, such as a metal spoon, is connected to the negative terminal of the power supply. A piece of silver is connected to the positive terminal. **The electrolyte is silver nitrate solution.**

Electroplating with copper

The object to be plated, such as a metal pan, is connected to the negative terminal of the power supply. A piece of copper is connected to the positive terminal. **The electrolyte is copper sulfate solution.**

This arrangement can also be used to **purify copper** during copper manufacture. In this case, both electrodes are made from copper. The negative electrode gradually gets coated with pure copper as the positive electrode gradually disappears.

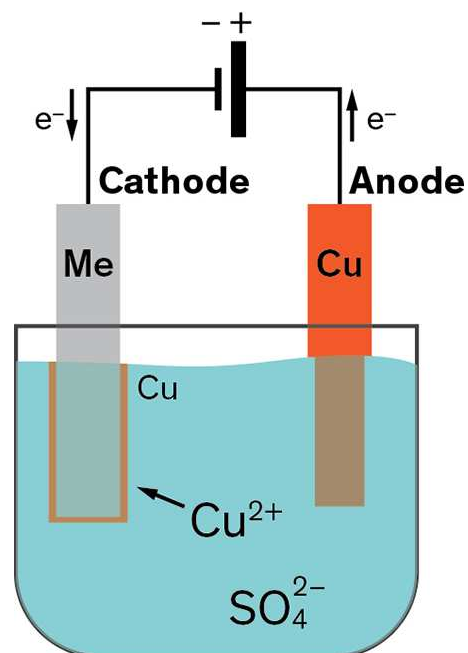

Manufacturing sodium hydroxide

Useful substances can be obtained by the **electrolysis of sodium chloride solution**.

During electrolysis:

- **chlorine gas** forms at the anode (positive electrode)
- **hydrogen gas** forms at the cathode (negative electrode)
- a solution of **sodium hydroxide** forms.

These products are **reactive**, so it is important to use **inert (unreactive) materials for the electrodes**.

A half-equation shows you what happens at one of the electrodes during electrolysis.

Electrons are shown as e^- .

These are the half-equations for this reaction:

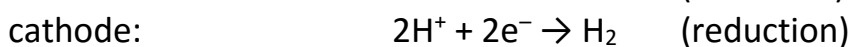
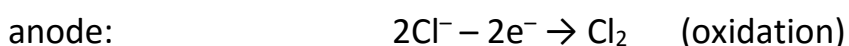

Oxidation happens at the anode because electrons are lost. Reduction happens at the cathode because electrons are gained.

Sodium ions, Na^+ , and **hydroxide ions, OH^-** , are also present in the sodium chloride solution. They are not discharged at the electrodes. Instead, they make **sodium hydroxide solution**.

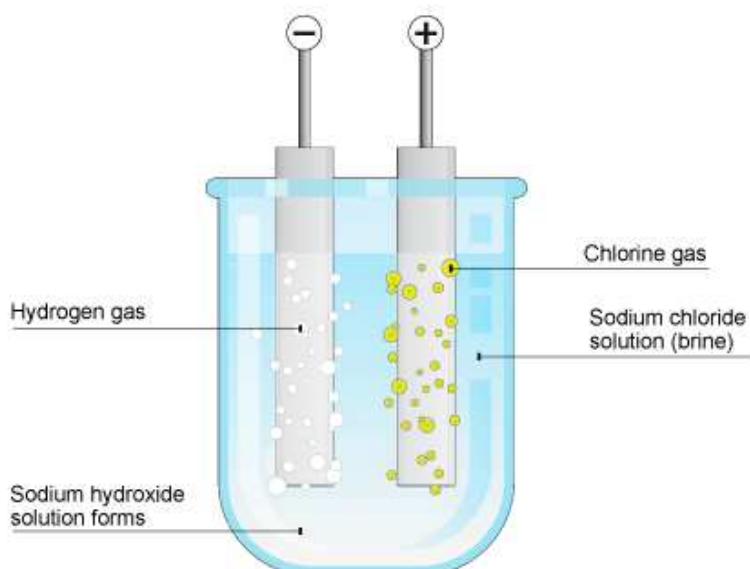

Topic 4 - CHEMICAL REACTIONS AND ENERGY

Exothermic and Endothermic reactions

Changes in temperature happen often during chemical reactions.

Exothermic reactions

An **exothermic** reaction is a reaction where the **temperature rises**. e.g. magnesium and acid.

Exothermic reactions will feel warm/hot. This is because energy is being **released** from the reaction to its surroundings.

Combustion and **neutralisation** are common examples of exothermic reactions.

Endothermic reactions

An **endothermic** reaction is a reaction where the **temperature falls**. e.g. ammonium nitrate and acid.

Endothermic reactions will feel cold. This is because energy is being **absorbed** by the reaction from its surroundings.

Examples are: electrolysis, the reaction between ethanoic acid and sodium carbonate and the thermal decomposition of calcium carbonate in a blast furnace.

Activation energy

Simple energy level diagrams only show the **energy levels** at the **beginning** and **end** of a reaction (like those above).

Energy levels **change gradually during a reaction**, and this can be shown using a curve between the reactant and product energy levels.

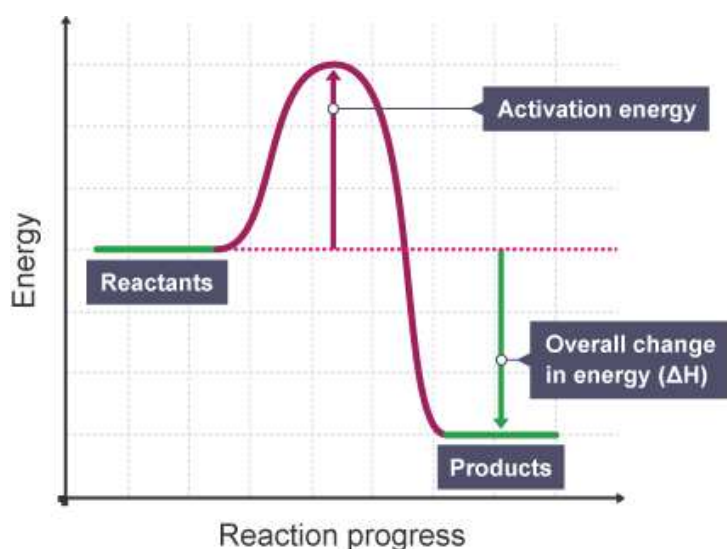

Exothermic Reaction

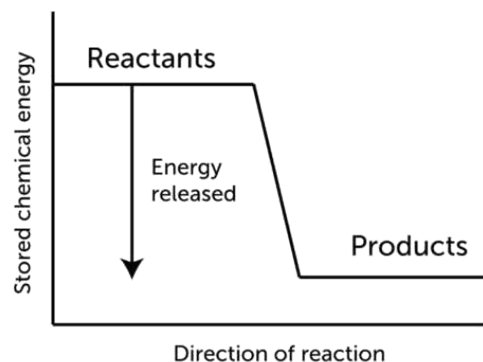

Endothermic Reaction

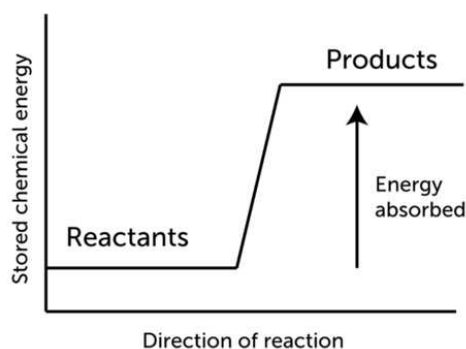

Notice that in this diagram, **energy is required to start the reaction**.

This is the **minimum amount** of energy required to start a reaction, and is known as the **activation energy**.

Notice that the overall change in energy during this diagram is **negative**...

The products have **less energy** than the reactants. This “lost” energy has been given out as **heat**. So, this reaction is **exothermic**.

Energy profiles

You will need to be able to sketch energy profiles for your exam, including labels.

Here are two common energy profiles:

Exothermic:

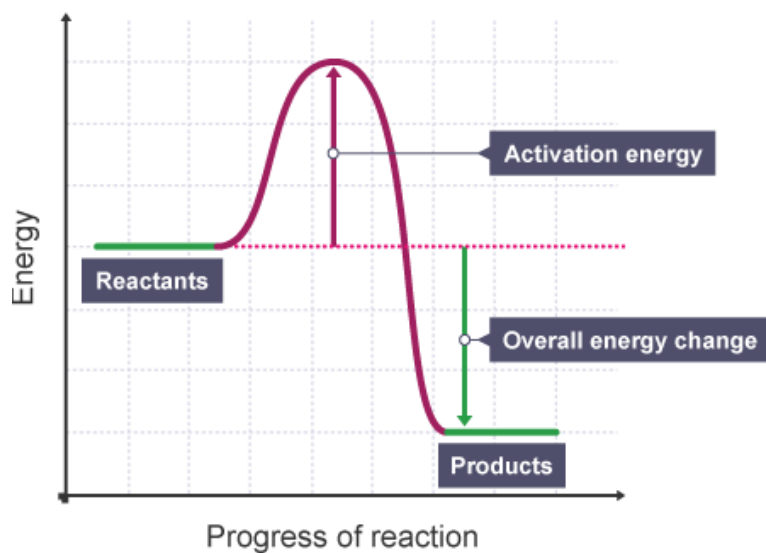

Notice that the overall energy change is **negative**.

This means energy is **given out** to its surroundings.

Endothermic:

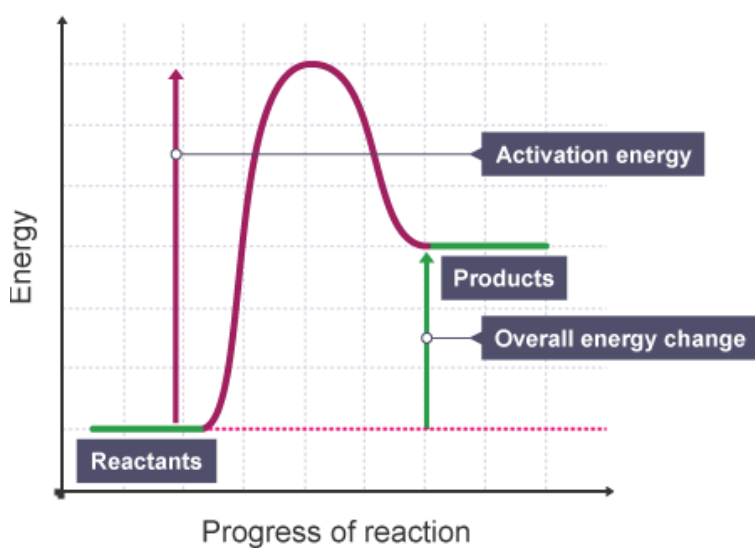

Notice that the overall energy change this time is **positive**.

This means energy is **taken from** its surroundings.

Often the activation energy required for endothermic reactions is large.

Bonds and energy

During a chemical reaction:

1. bonds in the **reactants** are broken
2. **new bonds are made** in the **products**

Energy is needed to **break bonds**, and **energy** is **released** when **bonds are made**.

In an **exothermic reaction**, more energy is released when new bonds are made than is needed to break existing bonds.

In an **endothermic reaction**, more energy is needed to break existing bonds than is released when new bonds are made.

Calculating bond energies

You can calculate the energy change in a reaction using **bond energies**. A bond energy is the amount of energy needed to break a mole of a particular bond. You will be given any bond energies you need in the exam.

Method

1. Add together all the bond energies to **break all the bonds in the reactants** – this is the ‘**energy in**’.
2. Add together the bond energies to **form all the bonds in the products** – this is the ‘**energy out**’.
3. Calculate the energy change: **energy in** – **energy out**.

Example 1 – an exothermic reaction

Hydrogen and chlorine react to form hydrogen chloride gas:



Bond energies relevant to this reaction:

| Bond | Bond Energy (kJ/mole) |
|-------|-----------------------|
| H-H | 436 |
| Cl-Cl | 243 |
| H-Cl | 432 |

$$\text{Energy in} = 436 \text{ (breaking H-H)} + 243 \text{ (breaking Cl-Cl)} = \underline{679 \text{ kJ/mole (Bonds broken)}}$$

$$\text{Energy out} = 2 \times 432 \text{ (forming H-Cl – twice)} = \underline{864 \text{ kJ/mole (Bonds formed)}}$$

$$\text{Energy change} = \text{Energy in} - \text{Energy out} = 679 - 864 = \underline{-185 \text{ kJ/mole}}$$

The **energy change is negative**, showing that energy is released to the surroundings in an **exothermic** reaction.

Bonds formed is larger than **bonds broken** so the reaction is **exothermic**.

Example 2 – an endothermic reaction

Hydrogen bromide decomposes to form hydrogen and bromine:



Bond energies relevant to this reaction:

| Bond | Bond Energy (kJ/mole) |
|-------|-----------------------|
| H-Br | 366 |
| H-H | 436 |
| Br-Br | 193 |

$$\text{Energy in} = 2 \times 366 = \underline{732 \text{ kJ/mole}}$$

$$\text{Energy out} = 436 + 193 = \underline{629 \text{ kJ/mole}}$$

$$\text{Energy change} = \text{Energy in} - \text{Energy out} = 732 - 629 = \underline{+103 \text{ kJ/mole}}$$

The **energy change is positive**, showing that energy is taken in from the surroundings in an **endothermic** reaction.

Bonds broken is larger than **bonds formed** so the reaction is **endothermic**.

Topic 5 - CRUDE OIL, FUELS AND ORGANIC CHEMISTRY

Crude oil is a **mixture** of a very large number of compounds. It is formed from the **remains of plants and animals which died millions of years ago**.

This is why it is called a **fossil fuel**.

Most of the compounds in crude oil consist of molecules made up of **hydrogen** and **carbon** atoms only, we call these type of compounds **hydrocarbons**. These are **separated** into useful products, such as fuels, using a process called **fractional distillation**.

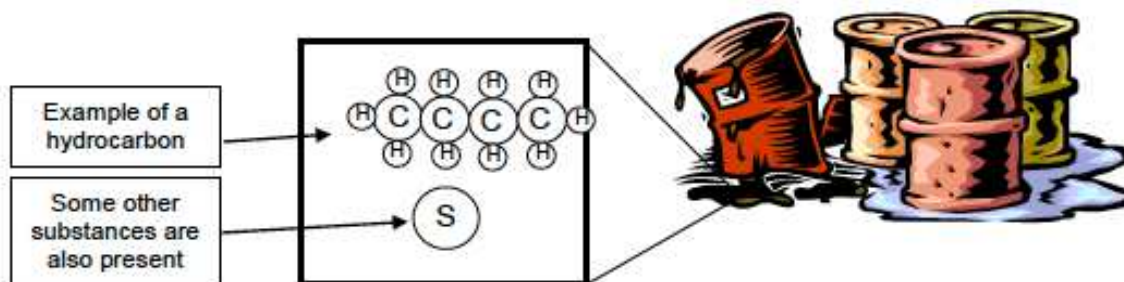

Carbon has the ability to **form bonds with other carbon** atoms resulting in the formation of **carbon atom chains**, e.g.



Crude oil contains a mixture of different sized hydrocarbon chains.

Environmental aspects

The exploitation of oil can **damage the environment** - for example, through **oil spills**.

Burning fossil fuels can also cause:

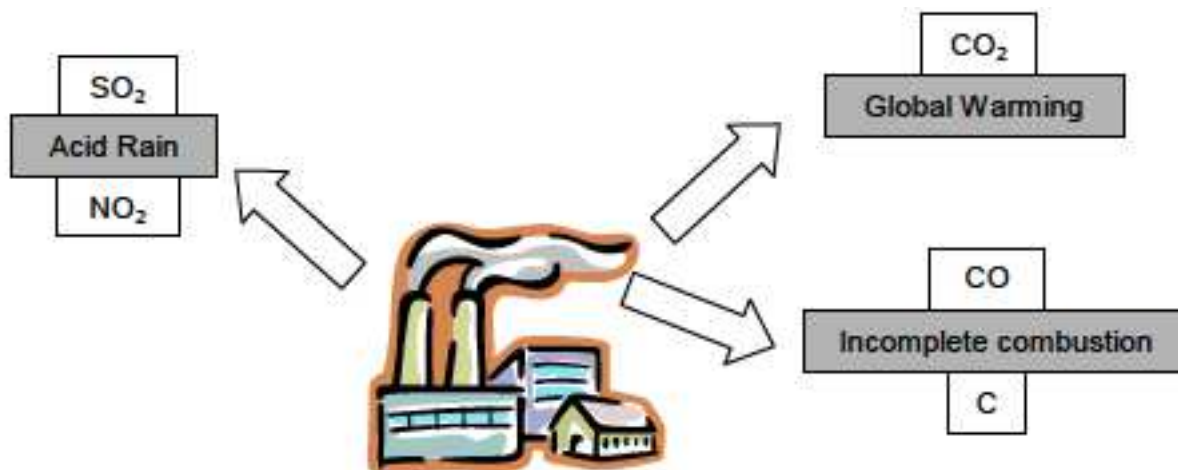

Fractional distillation

Crude oil is separated into **fractions**, this is done by **heating up the crude oil**.

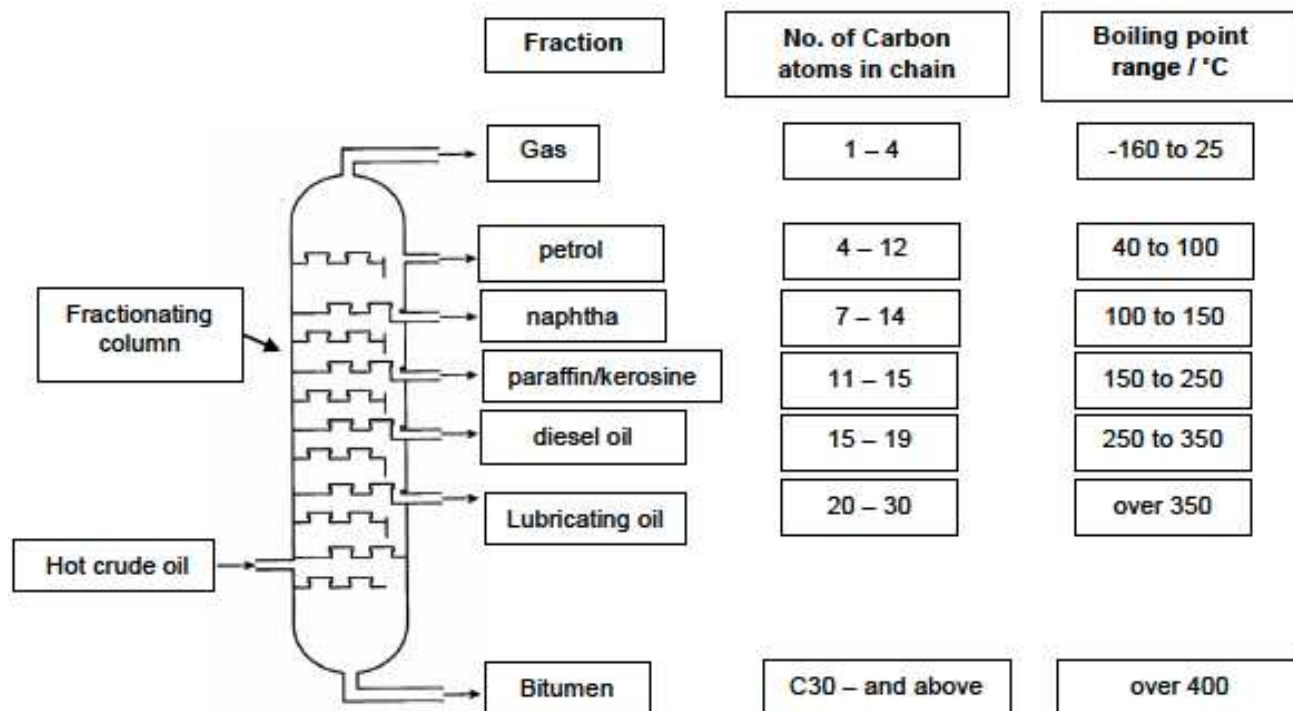

Fractions contain hydrocarbons with **boiling points** in the same range, e.g. the petrol fraction has hydrocarbons with boiling points in the range 40-100 °C.

Long chain hydrocarbons are at the **bottom** of the column as they **do not boil** until a **very high temperature**. Some of the fractions are used as fuels (e.g. Kerosene – aeroplane fuel) others are further processed by **cracking**.

Here are the main fractions in list. They are in increasing order from small molecules - gases - to large ones.

- LPG / “natural” gas - contains propane and butane, used in bottled cooking gas
- petrol - fuel for cars
- naphtha - used in the chemical industry
- paraffin/kerosene - aircraft fuels
- heating oil - diesel and heating
- fuel oils and lubricating oils - fuel for ships and power stations, lubrication
- bitumen - surfaces for roads and roofs

Hydrocarbons with **small molecules** make **better fuels** than hydrocarbons with large molecules, because they are **volatile**, **flow easily**, and are **easily ignited**.

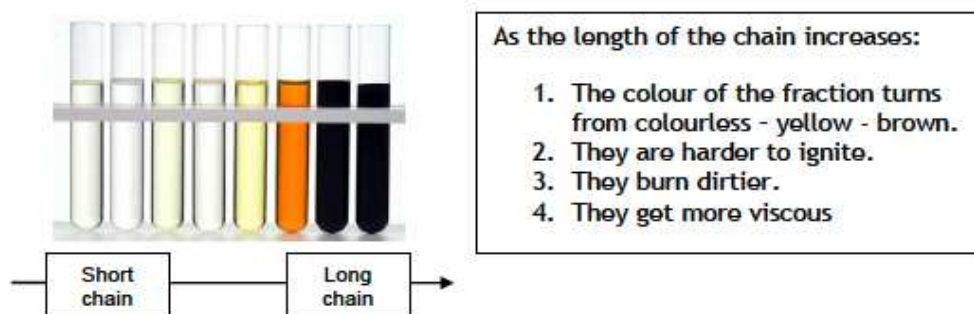

Combustion

Fuels are substances that react with **oxygen** to release useful energy. Most of the energy is released as heat, but light energy is also released.

About 21 per cent of the air is oxygen. When a fuel burns in plenty of air, it receives enough oxygen for **complete combustion**.

Hydrocarbons

Fuels such as natural gas and petrol contain **hydrocarbons**. These are compounds of hydrogen and carbon only. When they burn completely:

- the carbon oxidises to **carbon dioxide**
- the hydrogen oxidises to **water** - remember that water, H_2O , is an oxide of hydrogen
- combustion is **exothermic** – gives off heat

In general, for complete combustion:



Calculating the energy released

A simple experiment to determine the amount of energy released by a fuel.

Method

1. Measure 100cm^3 of water into the conical flask.
2. Clamp the flask at a suitable height so the spirit burner can be placed below it (as shown in the diagram - make sure that the thermometer does not touch the bottom of the flask).
3. Record the temperature of the water.
4. Record the mass of the spirit burner (including the lid and alcohol).
5. Place the spirit burner under the conical flask and light it.
6. Allow the burner to heat the water until the temperature rises by about 40°C . Record the temperature of the water.
7. Extinguish the flame carefully and record the mass of the burner.
8. Repeat steps 1-7 with each of the other alcohols.

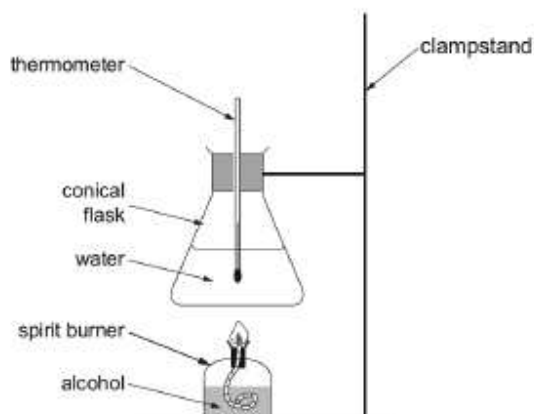

We can then:

1. Calculate the **temperature rise** for each fuel.
2. Calculate the mass of each alcohol burnt.
3. Calculate the energy released for each alcohol using an equation:

$$E = \text{mass} \times \text{increase in temperature} \times 4.2$$

Combustion of hydrogen

Hydrogen burns in oxygen to form water.

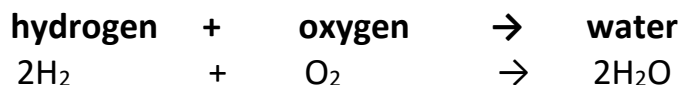

The flame is almost colour-less. Mixtures of hydrogen and oxygen (or hydrogen and air) can be **explosive** when the two gases are present in a particular ratio, so hydrogen must be **handled very carefully**.

Many people believe that because no carbon dioxide is released when it burns, hydrogen could be a **clean fuel** for use in the future - to replace fossil fuels that are causing **global warming**.

However, at the moment, most of the **hydrogen** used in the world is obtained from fossil fuels, so **carbon dioxide** is still released during the overall process.

Advantages

Produced from water therefore renewable and water is the only product of its combustion so burning hydrogen does not contribute towards global warming or acid rain.

Disadvantages

Requires large amounts of electricity to produce hydrogen from water by electrolysis (how is this generated?), storage requires bulky and heavy pressurised containers and is potentially hazardous as it forms an explosive mixture with air.

The fire triangle

The fire triangle is a simple way of understanding the factors essential for fire. Each side of the triangle represents one of the **three factors** required for the creation and maintenance of any fire; **oxygen, heat and fuel**.

Remove any one of these, the triangle is broken and the fire is stopped.

1. Removing Heat

Heat can be removed by the addition of something to reduce it. Water is used to put house fires and bonfires out.

2. Removing Oxygen

Cover things that are burning with foam, carbon dioxide or a fire blanket to remove the air supply.

- A fire blanket is used to extinguish a chip pan fire or a person on fire.
- Carbon dioxide powder is used to put out indoor fires, chemical and electrical fires.
- Foam is used to extinguish aircraft fire.

3. Removing Fuel

Without fuel a fire will stop. Switch off the electrical or gas supply. Fire-breaks are used to put forest fires out. This is when a section of trees is cleared deliberately to remove the fuel.



Cracking

The demand for short hydrocarbon molecules is greater than their supply in crude oil, so a reaction called **cracking** is used. **Cracking** converts long alkane molecules into shorter alkanes and alkenes, which are more useful.

At high temperatures, and with help from a catalyst, long hydrocarbon chains are broken down into smaller, more useful hydrocarbons including an **alkene**. One of the most common alkenes to be made is **ethene**.

Ethene is a small reactive molecule, a **monomer**. If **many ethene** molecules are linked together it is called polythene which is used to make many **plastics**.

Example:

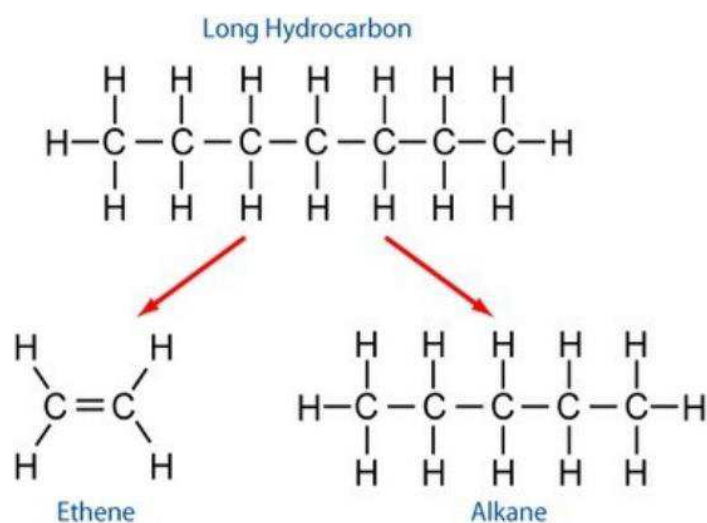

Creating Plastics

When small reactive molecules such as **ethene** react together in a chemical reaction a long chain molecule called a **polymer** is formed.

The process whereby monomers link to create a polymer is **polymerisation**:

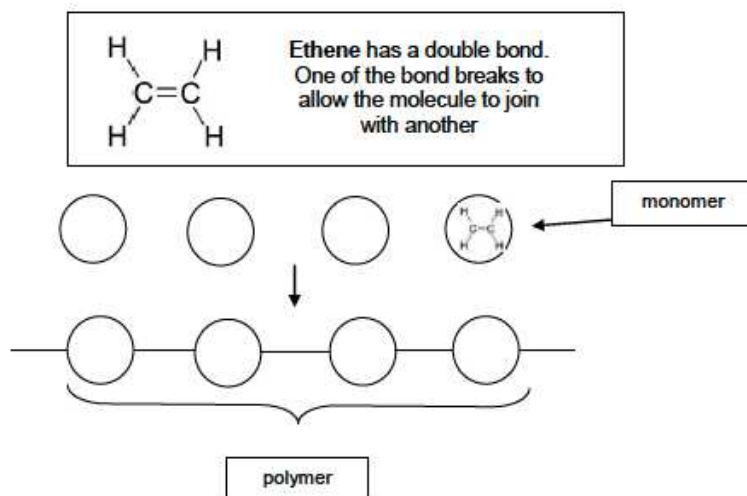

Alkanes

These are hydrocarbons with **single covalent bonds** between the carbon atoms. They are referred to as **saturated hydrocarbon** for this reason.

Alkanes have the general formula:

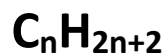

Alkanes are fairly unreactive, they combust well.

Here are the first five alkanes:

| Name | Formula | Structural Formula |
|---------|--------------------------------|----------------------------------------------------------------------------------------------------------|
| Methane | CH ₄ | <pre> H H-C-H H </pre> |
| Ethane | C ₂ H ₆ | <pre> H H H-C-C-H H H </pre> |
| Propane | C ₃ H ₈ | <pre> H H H H-C-C-C-H H H H </pre> |
| Butane | C ₄ H ₁₀ | <pre> H H H H H-C-C-C-C-H H H H H </pre> |
| Pentane | C ₅ H ₁₂ | <pre> H H H H H H-C-C-C-C-C-H H H H H H </pre> |

Single bond

Alkenes

When there are **double bonds** between two carbon atoms the name given to the group is **alkenes**. For this reason, they are described as **unsaturated** molecules.

Alkenes have the general formula:



| Name | Formula | Structural formula |
|---------|-------------------------------|------------------------------------------------------------------------------------------------------|
| Ethene | C ₂ H ₄ | <pre> H H \ / C=C / \ H H </pre> |
| Propene | C ₃ H ₆ | <pre> H H H \ / C=C-C-H / \ H H H </pre> |

As a result of the **double bond** the alkenes are **very reactive molecules**, the double bond can be broken to form single bonds with other atoms (**addition reaction**).

Higher tier

Isomers

In organic chemistry, isomers are molecules with the **same molecular formula** (i.e. the same number of atoms of each element), but different **structural** or spatial arrangements of the atoms within the molecule.

Isomer – has the same molecular formula but has a different structure.

Structural isomers of Butane:

| butane | methylpropane / 2-methylpropane |
|---------------------------------------------------------------------------------------------------------------------------------------------------------------------------------------------------------------------------------------------------|------------------------------------------------------------------------------------------------------------------------------------------------------------------------------------------------------------------------------------------------------------------------------------------------------|
| $ \begin{array}{cccc} & \text{H} & \text{H} & \text{H} & \text{H} \\ & & & & \\ \text{H} & -\text{C} & -\text{C} & -\text{C} & -\text{C}-\text{H} \\ & & & & \\ & \text{H} & \text{H} & \text{H} & \text{H} \end{array} $ | $ \begin{array}{ccccc} & & \text{H} & \text{H} & \text{H} \\ & & & & \\ \text{H} & -\text{C} & -\text{C} & -\text{C} & -\text{H} \\ & & & & \\ & & \text{H} & & \text{H} \\ & & & & \\ & & \text{H} & -\text{C} & -\text{H} \\ & & & & \\ & & & \text{H} & \end{array} $ |

Structural isomers of Pentane:

| pentane | 2-methylbutane | 2,2-di-methylpropane |
|-----------------------------------------------------------------------------------------------------------------------------------------------------------------------------------------------------------------------------------------------------------------------------------------------|-------------------------------------------------------------------------------------------------------------------------------------------------------------------------------------------------------------------------------------------------------------------------------------------------------------------------------------|--------------------------------------------------------------------------------------------------------------------------------------------------------------------------------------------------------------------------------------------------------------------------------------------------------------------------------------------------------------------------------------------------|
| $ \begin{array}{cccccc} & \text{H} & \text{H} & \text{H} & \text{H} & \text{H} \\ & & & & & \\ \text{H} & -\text{C} & -\text{C} & -\text{C} & -\text{C} & -\text{C}-\text{H} \\ & & & & & \\ & \text{H} & \text{H} & \text{H} & \text{H} & \text{H} \end{array} $ | $ \begin{array}{ccccc} & \text{H} & \text{H} & \text{H} & \text{H} \\ & & & & \\ \text{H} & -\text{C} & -\text{C} & -\text{C} & -\text{C}-\text{H} \\ & & & & \\ & \text{H} & & \text{H} & \text{H} \\ & & & & \\ & & \text{H} & -\text{C} & -\text{H} \\ & & & & \\ & & & \text{H} & \end{array} $ | $ \begin{array}{ccccc} & & & \text{H} & \\ & & & & \\ & & \text{H} & -\text{C} & -\text{H} \\ & & & & \\ & & \text{H} & & \text{H} \\ & & & & \\ \text{H} & -\text{C} & -\text{C} & -\text{C} & -\text{H} \\ & & & & \\ & \text{H} & & \text{H} & \text{H} \\ & & & & \\ & & \text{H} & -\text{C} & -\text{H} \\ & & & & \\ & & & \text{H} & \end{array} $ |

Positional isomers of Propanol

Positional isomers occur when the 'functional group' of the molecule changes position.

| propan-1-ol | Propan-2-ol |
|----------------------------------------------------------------------------------------------------------------------------------------------------------------------------------------------------------|----------------------------------------------------------------------------------------------------------------------------------------------------------------------------------------------------------|
| $ \begin{array}{cccc} & \text{H} & \text{H} & \text{H} \\ & & & \\ \text{H} & -\text{C} & -\text{C} & -\text{C}-\text{OH} \\ & & & \\ & \text{H} & \text{H} & \text{H} \end{array} $ | $ \begin{array}{cccc} & \text{H} & \text{H} & \text{H} \\ & & & \\ \text{H} & -\text{C} & -\text{C} & -\text{C}-\text{H} \\ & & & \\ & \text{H} & \text{OH} & \text{H} \end{array} $ |

Reactions of Alkenes

Addition reactions

Reaction with Hydrogen (Hydrogenation)

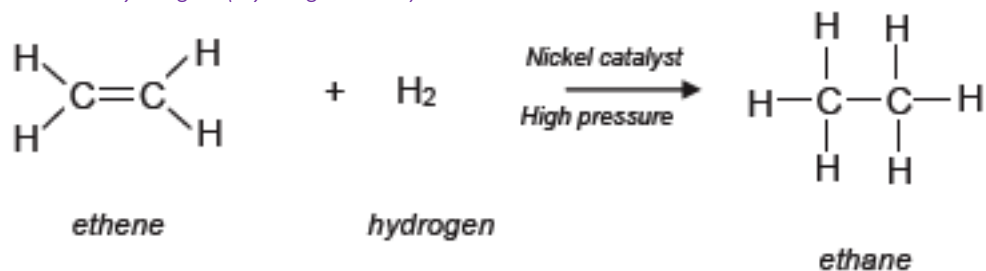

- Unsaturated Alkene becomes a saturated Alkane

Reaction with Bromine Water



- Addition of Bromine water is a test to see if an Alkene is present.

This reaction is a way of identifying alkenes.
Brown bromine water turns colourless

Addition polymerisation

Creating Plastics

When **small reactive molecules** such as **ethene** react together in a chemical reaction a long chain molecule is formed called a **polymer**.

Monomer is the name given to small reactive organic molecules that contain carbon=carbon double bonds.

The process whereby **monomers** link to create a **polymer** is **polymerisation**.

The type of polymerisation that happens here is **addition polymerisation** as there is only one product formed.

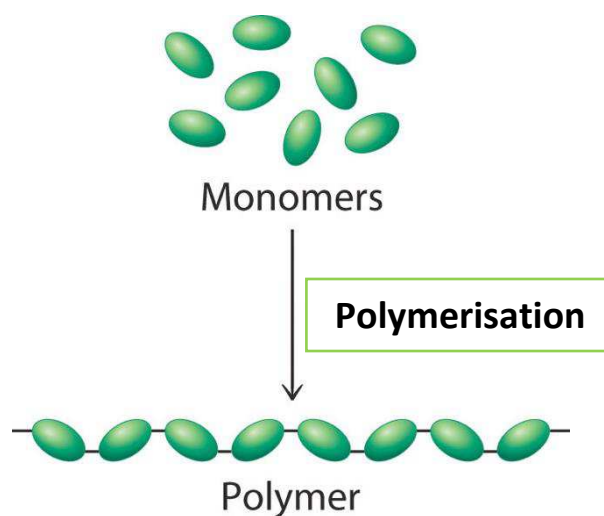

*Examples of polymerisation***1. Polythene**

The process of making **Polythene (poly(ethene))** is an example of addition polymerisation. The unsaturated monomers used are ethene.

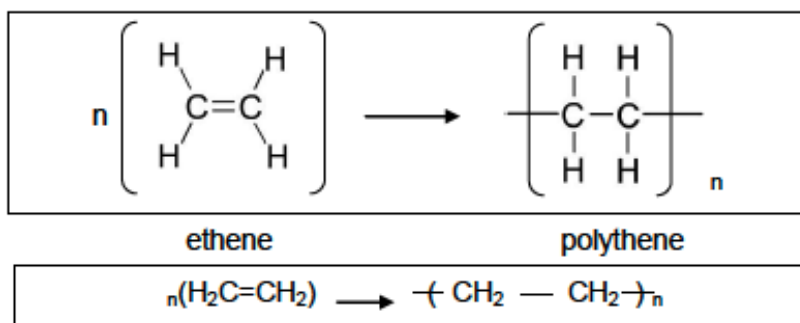
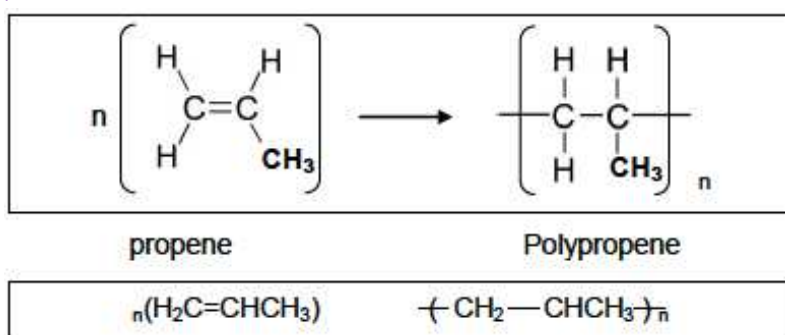
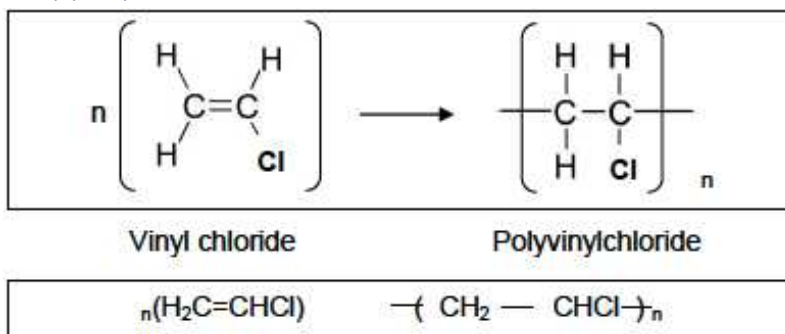
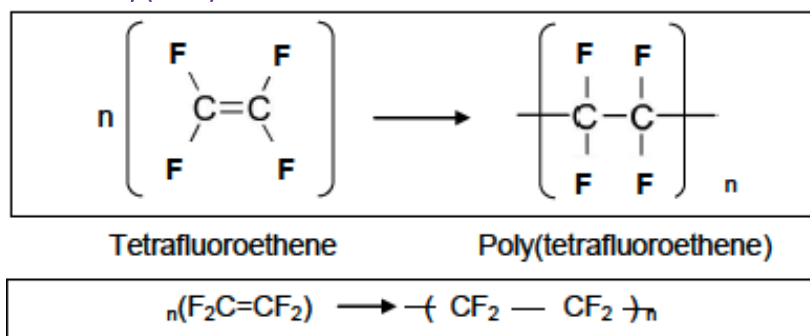
**2. Poly(propene)****3. Poly(vinylchloride) (PVC)****4. Poly(tetrafluoroethene) (PTFE)**

Properties and uses of plastics

Plastics are a group of very important materials that have a **wide variety of uses**. Plastics can be engineered for **specific uses** by matching up the **properties** of the plastic to the job it will ultimately be used for.

There are two main categories of plastic:

1. **Thermosoftening** (also called **thermoplastics**) are plastics which will soften when heated and can be reshaped.
2. **Thermosetting** plastics are plastics do not soften on heating. They are used when resistance to heat is important (e.g. kettles, plugs, laptop chargers etc.).

The properties and uses of some common **thermosoftening** plastics:

Polypropylene

Properties - Light, hard but scratches easily, tough, good resistance to chemicals, resists work fatigue

Uses - Medical equipment, laboratory equipment, containers with built-in hinges, 'plastic' seats, string, rope, kitchen equipment

Polystyrene

Properties - Light, hard, stiff, transparent, brittle, with good water resistance

Uses - Toys, especially model kits, packaging, 'plastic' boxes and containers

Low density polythene (LDPE)

Properties - Tough, good resistance to chemicals, flexible, fairly soft, good electrical insulator

Uses - Packaging, especially bottles, toys, packaging film and bags

High density polythene (HDPE)

Properties - Hard, stiff, able to be sterilised

Uses - Plastic bottles, tubing, household equipment



The properties and uses of some common **thermosetting** plastics:

Epoxy resin

Properties - Good electrical insulator, hard, brittle unless reinforced, resists chemicals well

Uses - Casting and encapsulation, adhesives, bonding of other materials

Urea formaldehyde

Properties - Stiff, hard, strong, brittle, good electrical insulator

Uses - Electrical fittings, handles and control knobs, adhesives



Specific uses that you need to be able to recall for the exam:

Polythene

Bags
Plastic bottles

Poly(propene)

Ropes
Crates

Poly(vinylchloride)

Drain pipes
Window frames

Poly(tetrafluoroethene)

Teflon –
Non-stick pans

Plastics and the environment

Buzzle.com

Nearly all plastics/polymers are **non-biodegradable**. This means that they will not rot away naturally either through the weather or by bacteria in soil, and can therefore cause a **long-term litter problem**.

There is another pollution problem produced when all **plastics burn**. As all plastics contain carbon, they can produce the **toxic gas carbon monoxide (CO)** when they are burned. However, some plastics can give off **other toxic gases** when they burn, depending on which elements are present in the formula of the plastic.



One of the useful properties of polymers is that they are **unreactive**, so they are suitable for storing food and chemicals safely. Unfortunately, this property makes it **difficult to dispose of polymers**. They can cause litter and are usually sent to landfill sites.

Most polymers, including poly(ethene) and poly(propene) are not biodegradable, so they may last for many years in rubbish dumps. However, it's possible to include substances such as corn-starch that cause the polymer to break down more quickly. Carrier bags and refuse bags made from such **degradable polymers** are available now.

Recycling

Many polymers can be **recycled**. This **reduces** the disposal problems and the **amount of crude oil used**. But the different polymers must be separated from each other first, and this can be difficult and expensive to do.

If a polymer/plastic can be recycled then it will have a symbol like these:

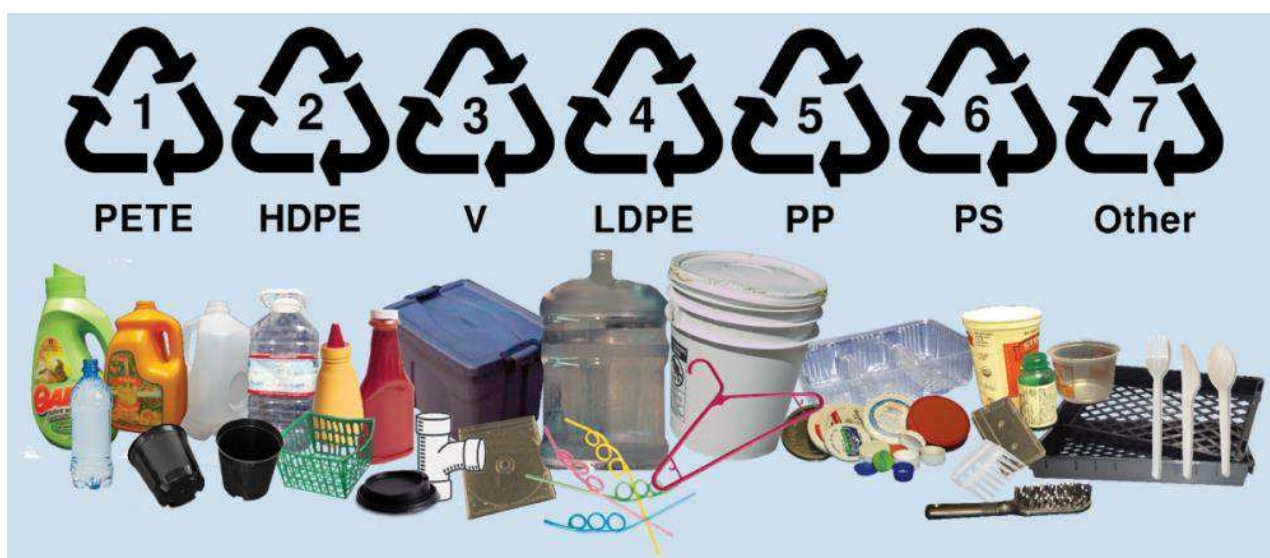

GCSE Chemistry ONLY

Double award – end of Unit 5 - Chemistry

Ethanol and Alcohols

Fermentation

Ethanol is produced from the **fermentation** of glucose by **yeast**.

Yeast is a living, single – cell microorganism that belongs to the fungi kingdom.

Yeast contains **enzymes** that catalyse the breakdown of glucose to ethanol and carbon dioxide.



Beer and **wine** are produced by fermenting glucose with yeast.

Enzymes

- Enzymes are **catalysts** formed from living cells
- A catalyst is a substance that **speeds up a reaction** (without getting used up in the process) and remains unchanged at the end
- Enzymes are globular proteins
- **Temperature** affects the reaction rates catalysed by enzymes.

Enzymes are used in **biotechnology** and in the baking, brewing and milk industries.

Fermentation reaction

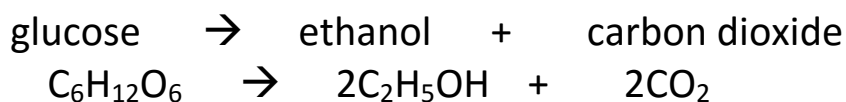

Conditions necessary for fermentation to occur

For the yeast enzymes to work they need:

- a glucose solution (glucose and water)
- a temperature in the range of 20-40°C
- absence of oxygen
- a pH in the range of 4 to 7

To obtain ethanol from the mixture, yeast is removed by **filtering**.

Then the ethanol and water (and some sugar) mixture is **distilled**.

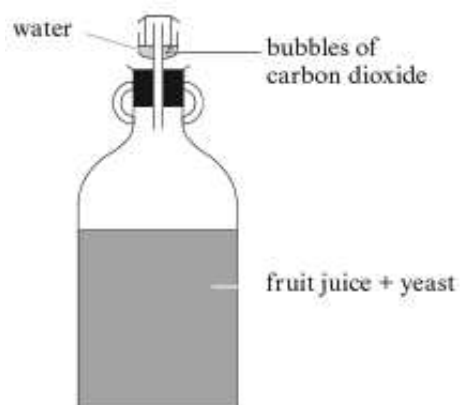

Making ethanol from ethene and steam

This is a more efficient method that is used in industry.

Ethanol can be made by reacting ethene (from cracking crude oil fractions) with steam. A catalyst of phosphoric acid is used to ensure a fast reaction.

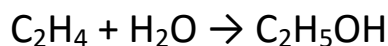

Notice that **ethanol** is the **only product**. The process is **continuous** – as long as ethene and steam are fed into one end of the reaction vessel, ethanol will be produced.

These features make it an **efficient process**, but there is a problem. Ethene is made from crude oil, which is a **non-renewable resource**. It cannot be replaced once it is used up and it will run out one day.

Ethanol - Health, Social and Economic impacts

Health problems with excessive use of alcohol over many years can include:

- liver or kidney damage
- vitamin deficiency
- heart disease
- memory loss
- depression
- stomach disorders
- cancer
- brain damage
- high blood pressure



Drinking excessively can lead to a number of harmful effects such as alcohol poisoning and cirrhosis of the liver.

*Alcohol poisoning**

Alcohol poisoning occurs when excessive amounts of alcohol start to interfere with the body's automatic functions such as:

- breathing
- heart rate
- gag reflex, which prevents you choking
-

Alcohol poisoning can cause a person to fall into a coma and could lead to their death.

*Cirrhosis of the liver**

Cirrhosis is scarring of the liver as a result of continuous, long-term liver damage. Scar tissue replaces healthy tissue in the liver and prevents the liver from working properly.

The damage caused by cirrhosis can't be reversed and eventually can become so extensive your liver stops functioning. This is called liver failure.

*NHS Direct

Social and economic impact of alcoholic drinks

Excessive use of alcohol can result in anti-social behaviour

- Aggressive behaviour
- Domestic violence
- Road accidents due to drink driving
- Wasting emergency services time
- Increases the cost of emergency services
- Tax on alcoholic drinks
- The tax raised from sale of alcoholic drinks generates significant revenue for the government.



Ethanol as a fuel

Ethanol can be produced from the fermentation of plants such as sugar cane. These are referred to as fuel crops and after distillation results in the production of **bioethanol**.

Bioethanol produces **only carbon dioxide** and **water** as waste products.



Bioethanol is **carbon neutral** because the carbon dioxide released during fermentation and combustion is equivalent to the amount **removed from the atmosphere** while the crop is growing.

Bioethanol is also **renewable**.

To **decrease** the **dependence on fossil fuels** and increase the energy from **renewable** sources, European governments have agreed to add some bioethanol to some petrol blends. Less sulfur dioxide will be formed which prevents acid rain forming.

Some critics warn of **deforestation**, and land being grabbed from food crops. This will increase **food poverty** as food prices are forced up.

Ethanol as a solvent

Not all substances dissolve in water. Ethanol is used extensively as a solvent:

- in the manufacture of varnishes and perfumes
- as a preservative for biological specimen
- in the preparation of essences and flavourings
- in many medicines
- as a disinfectant



Chemistry of Alcohols

The general formula for a simple alcohol:

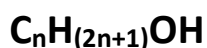

Here are some simple and common alcohols:

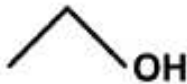
| Name | Molecular Formula | Structural formula | Skeletal structure |
|----------|----------------------------------|------------------------------------------------------------------------------------------------------------------------------------------------------------------------------------------------------------|--------------------------------------------------------------------------------------|
| Methanol | CH ₃ OH | $\begin{array}{c} \text{H} \\ \\ \text{H}-\text{C}-\text{OH} \\ \\ \text{H} \end{array}$ | |
| Ethanol | C ₂ H ₅ OH | $\begin{array}{c} \text{H} \quad \text{H} \\ \quad \\ \text{H}-\text{C}-\text{C}-\text{OH} \\ \quad \\ \text{H} \quad \text{H} \end{array}$ |  |
| Propanol | C ₃ H ₇ OH | $\begin{array}{c} \text{H} \quad \text{H} \quad \text{H} \\ \quad \quad \\ \text{H}-\text{C}-\text{C}-\text{C}-\text{OH} \\ \quad \quad \\ \text{H} \quad \text{H} \quad \text{H} \end{array}$ |  |

Functional groups

Functional groups are groups of atoms within molecules that are responsible for the **characteristic chemical reactions** of those molecules. The same functional group will undergo the same or similar chemical reaction(s) regardless of the size of the molecule it is a part of.

The functional group for **alkenes** is the **double bond** between the carbon atoms **C=C**.

The functional group for **alcohols** is the **-OH group**.

Higher tier

Positional isomers of Propanol

Positional isomers occur when the 'functional group' of the molecule changes position.

You will be required to name and draw positional isomers.

| propan-1-ol | Propan-2-ol |
|------------------------------------------------------------------------------------------------------------------------------------------------------------------------------------------------------------|------------------------------------------------------------------------------------------------------------------------------------------------------------------------------------------------------------|
| $\begin{array}{c} \text{H} \quad \text{H} \quad \text{H} \\ \quad \quad \\ \text{H}-\text{C}-\text{C}-\text{C}-\text{OH} \\ \quad \quad \\ \text{H} \quad \text{H} \quad \text{H} \end{array}$ | $\begin{array}{c} \text{H} \quad \text{H} \quad \text{H} \\ \quad \quad \\ \text{H}-\text{C}-\text{C}-\text{C}-\text{H} \\ \quad \quad \\ \text{H} \quad \text{OH} \quad \text{H} \end{array}$ |

Oxidation of alcohols

Alcohols are oxidised to carboxylic acids with acidified potassium dichromate:

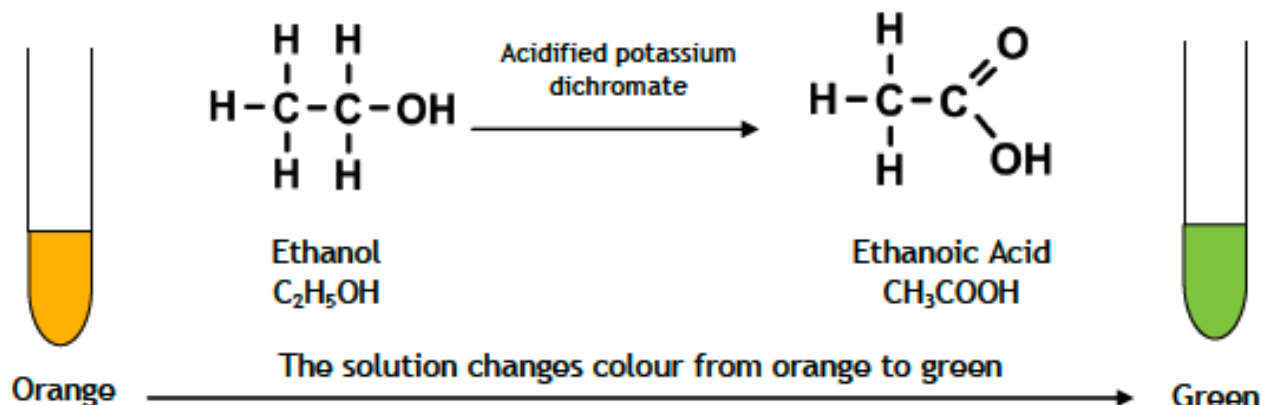

The early breathalyser

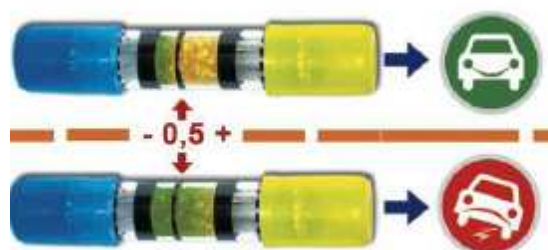

The oxidation reaction above was the basis of the early breathalyser. Tubes were used that contained orange dichromate crystals, the driver blew through the tube, if the driver had been drinking alcohol the crystals would turn green, the amount of crystals that were changed to green corresponded to the amount of alcohol in the drivers breath. More accurate techniques such as infrared are used in police stations today.

Higher tier

Infrared Spectroscopy

Infrared spectroscopy is used to **identify** the presence of **certain bonds** in organic molecules. All bonds in a molecule vibrate; **different bonds** will vibrate at **different frequencies**.

The absorption values will be given in the exam, examples are shown below:

| Infrared spectroscopy characteristic absorption values | |
|--------------------------------------------------------|-------------------------------|
| Bond | Wavenumber / cm^{-1} |
| C-O | 1000 - 1300 |
| C=C | 1620 - 1670 |
| C=O | 1650 - 1750 |
| C-H | 2800 - 3100 |
| O-H | 2500 - 3550 |

The infrared spectrum below shows the characteristic frequencies for Ethanol:

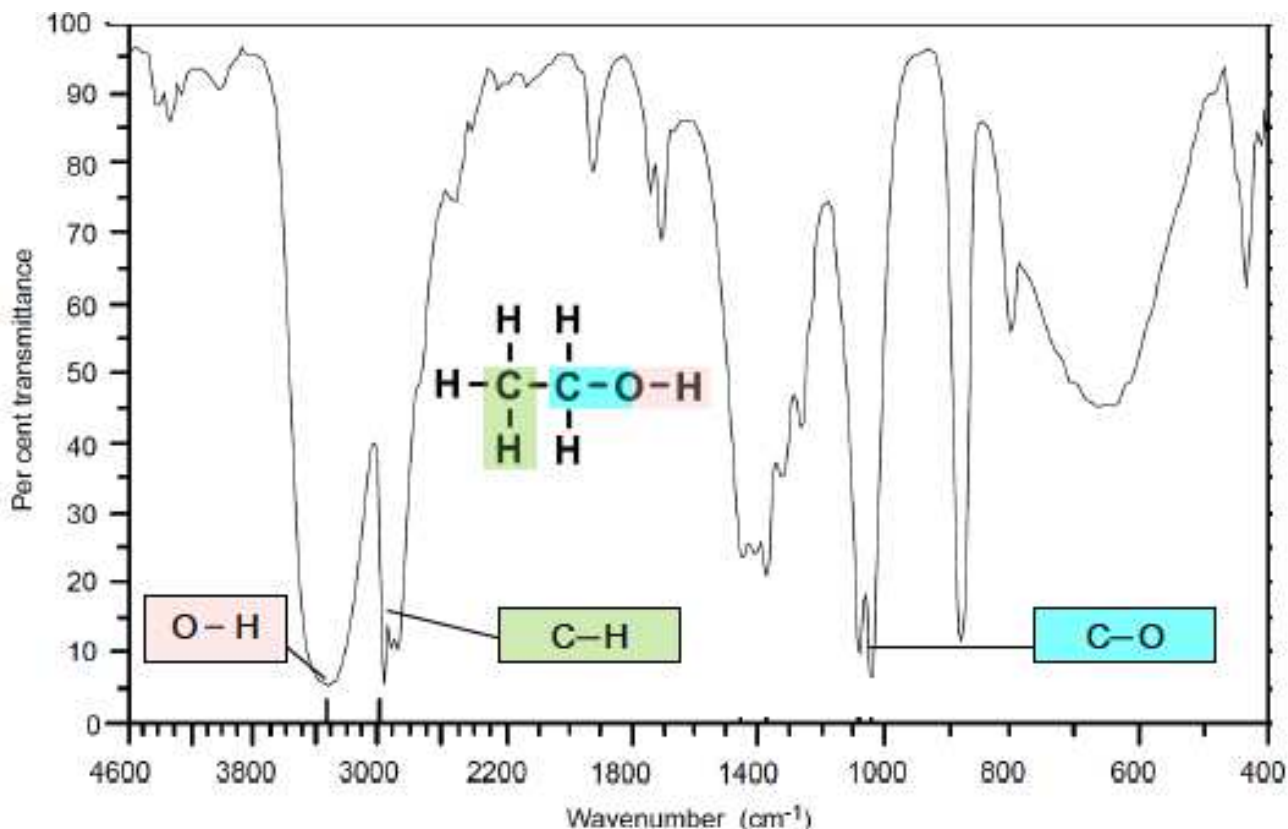

Infrared spectroscopy can be used as a tool to **identify important functional groups** in a molecule. It can also be used to check if reactions have been successful.

Consider the reaction of ethanol with acidified potassium dichromate, in this reaction ethanol is oxidised to ethanoic acid.

The infrared spectrum of the ethanoic acid produced:

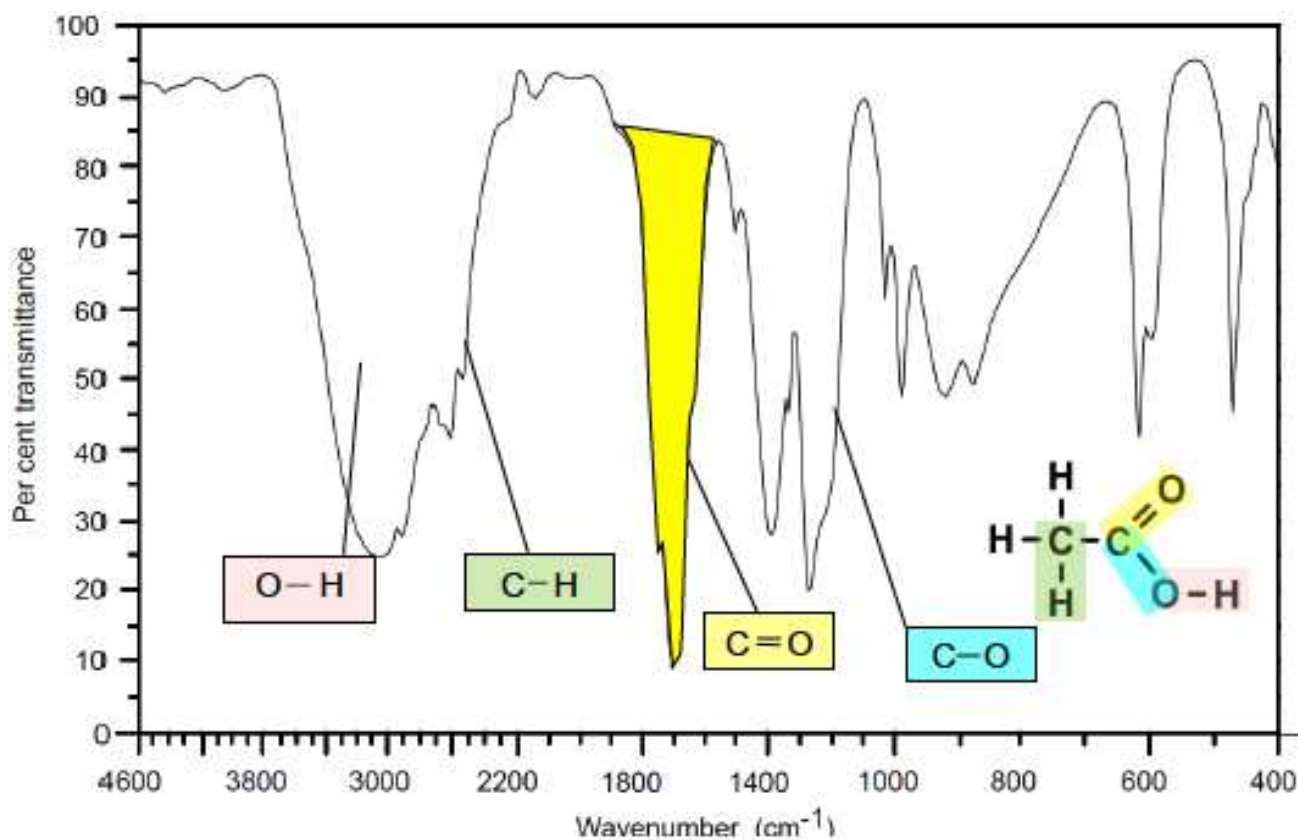

The appearance of the peak at 1700 cm⁻¹ (C=O) proves that ethanol has been **oxidised**. This was not present in the infrared spectrum of ethanol. This spectrum is typical of a carboxylic acid which has the C=O and -OH groups (-COOH).

Uses of Infrared Spectroscopy (IR)

As spectroscopic techniques are **simple**, **fast** and **accurate** they have replaced the need for chemical test in large laboratories.

Spectroscopy is an important tool in drug development for medicine and the development of new products in industry.

Topic 6 - REVERSIBLE REACTIONS, INDUSTRIAL PROCESSES AND IMPORTANT CHEMICALS

(GCSE Chemistry ONLY)

Reversible reactions

Many reactions, such as burning fuel, are **irreversible** - they go to completion and cannot be reversed easily. **Reversible** reactions are different. In a reversible reaction, the **products** can react to produce the **original reactants** again.

When writing chemical equations for reversible reactions, we do not use the usual one-way arrow. Instead, we use two arrows, each with just half an arrowhead - the top one pointing right, and the bottom one pointing left. For example:



The equation shows that ammonium chloride (a white solid) can break down to form ammonia and hydrogen chloride. It also shows that ammonia and hydrogen chloride (colourless gases) can react to form ammonium chloride again.

If the forward reaction is **exothermic**, the backward reaction is **endothermic** and that the same amount of heat is transferred in both directions.

Haber process – industrial manufacturing of ammonia

Hydrogen and atmospheric nitrogen need to react to form **ammonia**. This reaction is a **reversible reaction**. This means the reaction can go forwards or backwards depending on the conditions.

The theoretical conditions needed for a high yield, forward reaction to occur would be low temperature with high pressure.

The word and symbol equations:

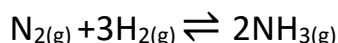

The conditions used in the manufacture of ammonia are:

- 350-450°C (*relatively high temperature*)
- 150-200 atmospheres (*relatively low pressure*)
- Iron catalyst

This is an **exothermic reaction** that creates liquid ammonia on condensing.

From an industrial point of view, a **lower temperature** would cause the process to be **too slow**. This explains the moderately **high temperature** chosen.

A pressure of 150-200 atmospheres is used, as creating equipment to maintain a **higher pressure** is **too expensive**.

The yield is compromised to 15-40%. The unreacted nitrogen and hydrogen are recycled. This way the greatest amount of ammonia per day/week/month is achieved.

The following graph illustrates the effect of temperature and pressure on the yield of ammonia formed:

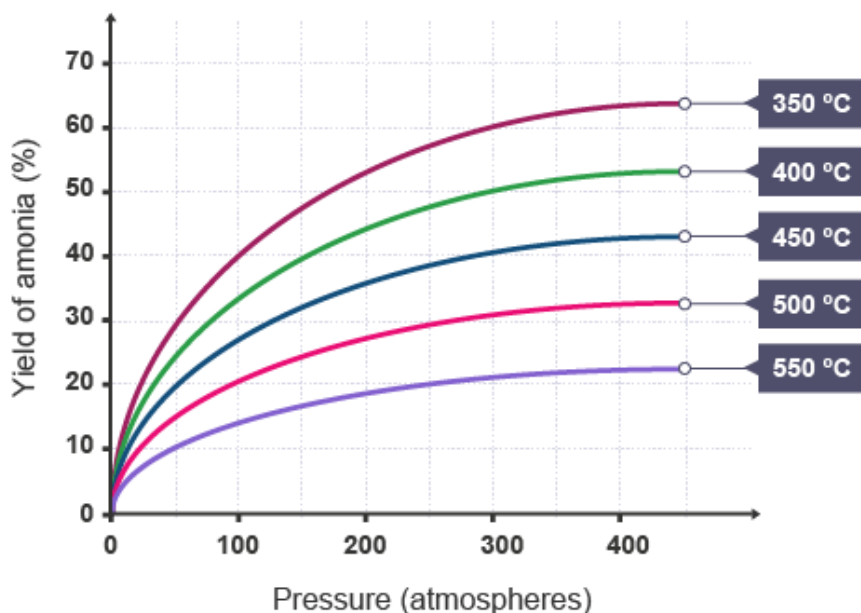

Although the iron catalyst speeds up the reaction, over time this will become **poisoned** and will reduce the speed at which ammonia is created.

Here is a diagram to show how ammonia is formed and the unreacted gases recycled:

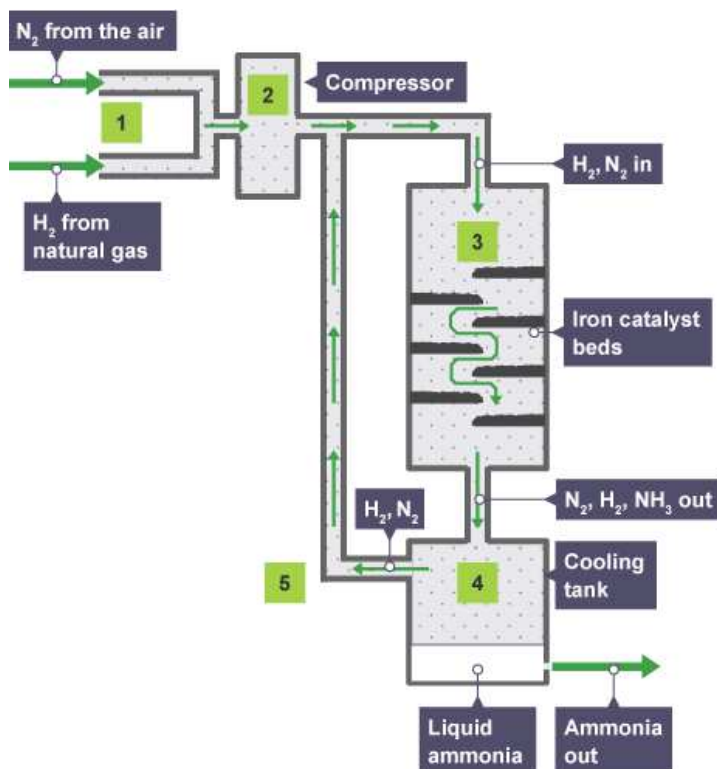

Stage 1 - Having obtained the hydrogen and nitrogen gases (from natural gas and the air respectively), they are pumped into the compressor through pipes.

Stage 2 - The gases are pressurised to about 200 atmospheres of pressure inside the compressor.

Stage 3 - The pressurised gases are pumped into a tank containing beds of iron catalyst at about 450°C. In these conditions, some of the hydrogen and nitrogen will react to form ammonia.

Stage 4 - The unreacted nitrogen and hydrogen, together with the ammonia, pass into a cooling tank. The cooling tank liquefies the ammonia, which can be removed into pressurised storage vessels.

Stage 5 - The unreacted hydrogen and nitrogen gases are recycled by being fed back through pipes to pass through the hot iron catalyst beds again.

Contact process - industrial manufacturing of sulfuric acid

The raw materials needed to make sulfuric acid are:

- sulfur
- air
- water

Stage 1: Making sulfur dioxide

In the first stage of the Contact process, sulfur is burned in air to make sulfur dioxide:

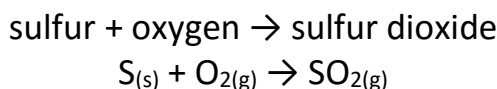

Notice that this is **not** a reversible reaction.

Stage 2: Making sulfur trioxide

In the second stage, sulfur dioxide reacts with more oxygen to make sulfur trioxide:

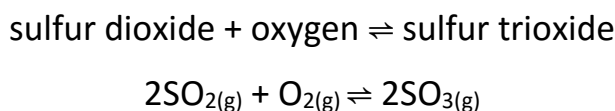

Notice that this reaction **is** reversible. The conditions needed for it are:

- a catalyst of vanadium(V) oxide, V_2O_5
- a temperature of around 450°C
- atmospheric pressure

Stage 3: Making sulfuric acid

In the final stage, sulfur trioxide reacts with water to make sulfuric acid:

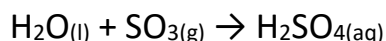

Notice that this is **not** a reversible reaction, just like the first stage.

Sulfur trioxide is absorbed in sulfuric acid (98% H_2SO_4 , 2% water). Sulfur trioxide cannot be absorbed directly in 100% water, as the **reaction is violent** and produces a mist of the acid. The SO_3 reacts with the small quantity of water.

What are the uses of Sulfuric Acid?

- The acid in a car battery.
- Making detergents.
- Metal treatment and anodising.
- A catalyst.
- A dehydrating agent.
- Making fertiliser.
- Paints and dyes.

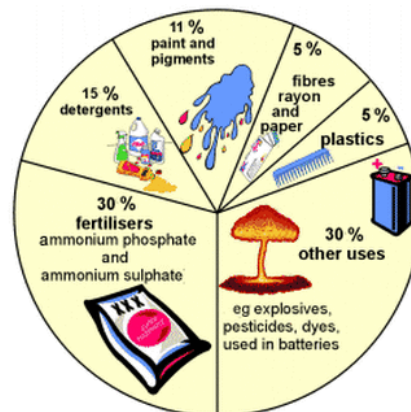

Sulfuric acid as a dehydrating agent

Dehydration means **removing water** from a substance. **Concentrated sulfuric acid** is very good at **dehydration**.

Example 1.

Blue copper(II) sulfate crystals contain water. Five water molecules surround each copper sulfate particle.

Concentrated sulfuric acid takes away the water molecules and the copper sulfate becomes white.

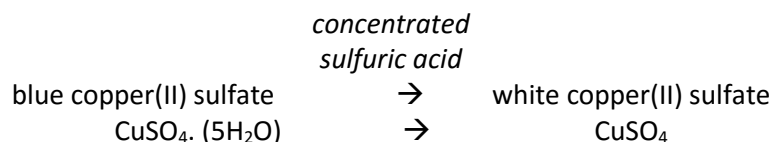

White copper(II) sulfate is called **anhydrous** and is used as a test for water.

Example 2.

Glucose is a sugar which is made in the leaves of plants during photosynthesis. It does not contain water molecules but does contain hydrogen and oxygen which are the elements of water.

Glucose has the formula C₆H₁₂O₆.

Concentrated sulfuric acid will take away the elements of water from glucose leaving **only carbon**.

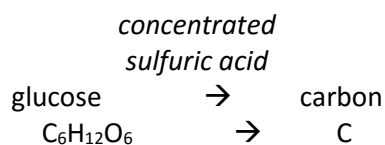

The water which is removed in these examples dissolves in the concentrated sulfuric acid and makes it more dilute.



Fertilisers

The majority of sulfuric acid that is produced is used to make **fertilisers**. This is often by neutralising the sulfuric acid with ammonia (alkaline), or ammonium hydroxide solution, to make ammonium sulfate, $(\text{NH}_4)_2\text{SO}_4$.



Nitric acid can be used instead of sulfuric, this produces ammonium nitrate.

These are nitrogen rich compounds which are spread on farmlands for better plant growth. When these dissolve in rainwater **nitrogen** is released to the soil. Healthy plants need **nitrogen** to make protein.

Advantages and disadvantages of fertilizers

Advantages

- ✓ Increases crop yields
- ✓ Healthier plants
- ✓ Relatively cheap
- ✓ Improves poor quality land

Disadvantages

- ✗ Eutrophication
- ✗ Could enter water supply → Blue baby syndrome

Eutrophication

If large amounts of fertilisers, especially nitrates, are washed out of the soil into rivers/lakes they can seriously unbalance the equilibria of the natural food chains and life cycles.

Fertilisers are used up by water plants which rapidly cover the water.

Underwater plants die and decompose as they do not get enough sunlight, as a result creatures such as fish die as the oxygen has been used up by decomposing bacteria.

The result is an overgrowth of algae.

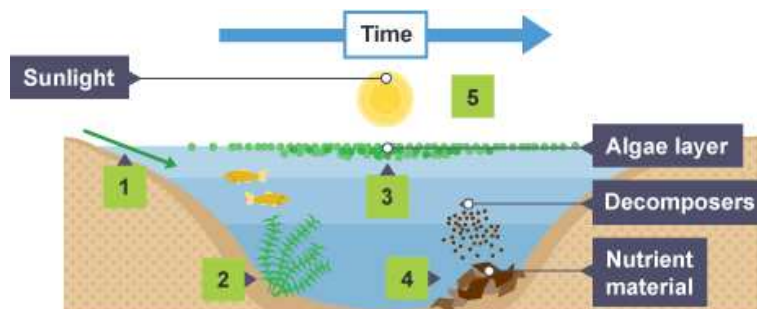

- 1 Nutrient load up: excessive nutrients from fertilisers are flushed from the land into rivers or lakes by rainwater.
- 2 Plants flourish: these pollutants cause aquatic plant growth of algae, duckweed and other plants.
- 3 Algae blooms, oxygen is depleted: algae blooms prevent sunlight reaching other plants. The plants die and oxygen in the water is depleted.
- 4 Decomposition further depletes oxygen: dead plants are broken down by bacteria decomposers, using up even more oxygen in the water.
- 5 Death of the ecosystem: oxygen levels reach a point where no life is possible. Fish and other organisms die.

Identification of ammonia and ammonium

Ammonia – identifying ammonium salt

If a salt containing **ammonium (NH_4^+)** reacts with **hydroxide ions (OH^-)** it forms **ammonia (NH_3)** gas.

Ammonia gas will change
damp red litmus paper blue.

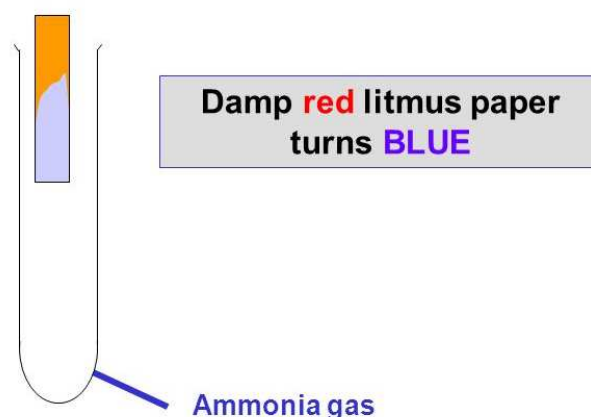

The litmus turns BLUE because ammonia is ALKALINE
You can also recognise it from its pungent SMELL

An example of this test is:

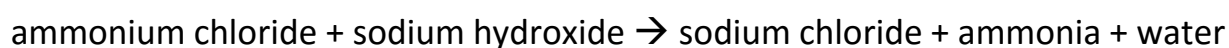

Table of Ions

| POSITIVE IONS | | NEGATIVE IONS | |
|---------------|------------------|---------------|--------------------|
| Name | Formula | Name | Formula |
| Aluminium | Al^{3+} | Bromide | Br^- |
| Ammonium | NH_4^+ | Carbonate | CO_3^{2-} |
| Barium | Ba^{2+} | Chloride | Cl^- |
| Calcium | Ca^{2+} | Fluoride | F^- |
| Copper(II) | Cu^{2+} | Hydroxide | OH^- |
| Hydrogen | H^+ | Iodide | I^- |
| Iron(II) | Fe^{2+} | Nitrate | NO_3^- |
| Iron(III) | Fe^{3+} | Oxide | O^{2-} |
| Lithium | Li^+ | Sulfate | SO_4^{2-} |
| Magnesium | Mg^{2+} | | |
| Nickel | Ni^{2+} | | |
| Potassium | K^+ | | |
| Silver | Ag^+ | | |
| Sodium | Na^+ | | |
| Zinc | Zn^{2+} | | |

Periodic Table of Elements

| 1 | | 2 | | Group | | | | | | | | | | 3 | 4 | 5 | 6 | 7 | 0 | |
|-------------------------------------------------------------------|-------------------------------------------------------------------|--------------------------------------------------------------------|-------------------------------------------------------------------|-------------------------------------------------------------------|--------------------------------------------------------------------|--------------------------------------------------------------------|--------------------------------------------------------------------|------------------------------------------------------------------|--------------------------------------------------------------------|-----------------------------------------------------------------|------------------------------------------------------------------|-------------------------------------------------------------------|-------------------------------------------------------------------|-------------------------------------------------------------------|--------------------------------------------------------------------|-------------------------------------------------------------------|-----------------------------------------------------------------|---|---|----------------------------------------------------------------|
| | | | | $\begin{array}{c} 1 \\ \text{H} \\ \text{Hydrogen} \end{array}$ | | | | | | | | | | | | | | | | $\begin{array}{c} 4 \\ \text{He} \\ \text{Helium} \end{array}$ |
| $\begin{array}{c} 7 \\ 3 \\ \text{Li} \end{array}$ Lithium | $\begin{array}{c} 9 \\ 4 \\ \text{Be} \end{array}$ Beryllium | | | | | | | | | | | $\begin{array}{c} 11 \\ 5 \\ \text{B} \end{array}$ Boron | $\begin{array}{c} 12 \\ 6 \\ \text{C} \end{array}$ Carbon | $\begin{array}{c} 14 \\ 7 \\ \text{N} \end{array}$ Nitrogen | $\begin{array}{c} 16 \\ 8 \\ \text{O} \end{array}$ Oxygen | $\begin{array}{c} 19 \\ 9 \\ \text{F} \end{array}$ Fluorine | $\begin{array}{c} 20 \\ 10 \\ \text{Ne} \end{array}$ Neon | | | |
| $\begin{array}{c} 23 \\ 11 \\ \text{Na} \end{array}$ Sodium | $\begin{array}{c} 24 \\ 12 \\ \text{Mg} \end{array}$ Magnesium | | | | | | | | | | | $\begin{array}{c} 27 \\ 13 \\ \text{Al} \end{array}$ Aluminium | $\begin{array}{c} 28 \\ 14 \\ \text{Si} \end{array}$ Silicon | $\begin{array}{c} 31 \\ 15 \\ \text{P} \end{array}$ Phosphorus | $\begin{array}{c} 32 \\ 16 \\ \text{S} \end{array}$ Sulfur | $\begin{array}{c} 35 \\ 17 \\ \text{Cl} \end{array}$ Chlorine | $\begin{array}{c} 40 \\ 18 \\ \text{Ar} \end{array}$ Argon | | | |
| $\begin{array}{c} 39 \\ 19 \\ \text{K} \end{array}$ Potassium | $\begin{array}{c} 40 \\ 20 \\ \text{Ca} \end{array}$ Calcium | $\begin{array}{c} 45 \\ 21 \\ \text{Sc} \end{array}$ Scandium | $\begin{array}{c} 48 \\ 22 \\ \text{Ti} \end{array}$ Titanium | $\begin{array}{c} 51 \\ 23 \\ \text{V} \end{array}$ Vanadium | $\begin{array}{c} 52 \\ 24 \\ \text{Cr} \end{array}$ Chromium | $\begin{array}{c} 55 \\ 25 \\ \text{Mn} \end{array}$ Manganese | $\begin{array}{c} 56 \\ 26 \\ \text{Fe} \end{array}$ Iron | $\begin{array}{c} 59 \\ 27 \\ \text{Co} \end{array}$ Cobalt | $\begin{array}{c} 59 \\ 28 \\ \text{Ni} \end{array}$ Nickel | $\begin{array}{c} 64 \\ 29 \\ \text{Cu} \end{array}$ Copper | $\begin{array}{c} 65 \\ 30 \\ \text{Zn} \end{array}$ Zinc | $\begin{array}{c} 70 \\ 31 \\ \text{Ga} \end{array}$ Gallium | $\begin{array}{c} 73 \\ 32 \\ \text{Ge} \end{array}$ Germanium | $\begin{array}{c} 75 \\ 33 \\ \text{As} \end{array}$ Arsenic | $\begin{array}{c} 79 \\ 34 \\ \text{Se} \end{array}$ Selenium | $\begin{array}{c} 80 \\ 35 \\ \text{Br} \end{array}$ Bromine | $\begin{array}{c} 84 \\ 36 \\ \text{Kr} \end{array}$ Krypton | | | |
| $\begin{array}{c} 86 \\ 37 \\ \text{Rb} \end{array}$ Rubidium | $\begin{array}{c} 88 \\ 38 \\ \text{Sr} \end{array}$ Strontium | $\begin{array}{c} 89 \\ 39 \\ \text{Y} \end{array}$ Yttrium | $\begin{array}{c} 91 \\ 40 \\ \text{Zr} \end{array}$ Zirconium | $\begin{array}{c} 93 \\ 41 \\ \text{Nb} \end{array}$ Niobium | $\begin{array}{c} 96 \\ 42 \\ \text{Mo} \end{array}$ Molybdenum | $\begin{array}{c} 99 \\ 43 \\ \text{Tc} \end{array}$ Technetium | $\begin{array}{c} 101 \\ 44 \\ \text{Ru} \end{array}$ Ruthenium | $\begin{array}{c} 103 \\ 45 \\ \text{Rh} \end{array}$ Rhodium | $\begin{array}{c} 106 \\ 46 \\ \text{Pd} \end{array}$ Palladium | $\begin{array}{c} 108 \\ 47 \\ \text{Ag} \end{array}$ Silver | $\begin{array}{c} 112 \\ 48 \\ \text{Cd} \end{array}$ Cadmium | $\begin{array}{c} 115 \\ 49 \\ \text{In} \end{array}$ Indium | $\begin{array}{c} 119 \\ 50 \\ \text{Sn} \end{array}$ Tin | $\begin{array}{c} 122 \\ 51 \\ \text{Sb} \end{array}$ Antimony | $\begin{array}{c} 128 \\ 52 \\ \text{Te} \end{array}$ Tellurium | $\begin{array}{c} 127 \\ 53 \\ \text{I} \end{array}$ Iodine | $\begin{array}{c} 131 \\ 54 \\ \text{Xe} \end{array}$ Xenon | | | |
| $\begin{array}{c} 133 \\ 55 \\ \text{Cs} \end{array}$ Caesium | $\begin{array}{c} 137 \\ 56 \\ \text{Ba} \end{array}$ Barium | $\begin{array}{c} 139 \\ 57 \\ \text{La} \end{array}$ Lanthanum | $\begin{array}{c} 179 \\ 72 \\ \text{Hf} \end{array}$ Hafnium | $\begin{array}{c} 181 \\ 73 \\ \text{Ta} \end{array}$ Tantalum | $\begin{array}{c} 184 \\ 74 \\ \text{W} \end{array}$ Tungsten | $\begin{array}{c} 186 \\ 75 \\ \text{Re} \end{array}$ Rhenium | $\begin{array}{c} 190 \\ 76 \\ \text{Os} \end{array}$ Osmium | $\begin{array}{c} 192 \\ 77 \\ \text{Ir} \end{array}$ Iridium | $\begin{array}{c} 195 \\ 78 \\ \text{Pt} \end{array}$ Platinum | $\begin{array}{c} 197 \\ 79 \\ \text{Au} \end{array}$ Gold | $\begin{array}{c} 201 \\ 80 \\ \text{Hg} \end{array}$ Mercury | $\begin{array}{c} 204 \\ 81 \\ \text{Tl} \end{array}$ Thallium | $\begin{array}{c} 207 \\ 82 \\ \text{Pb} \end{array}$ Lead | $\begin{array}{c} 209 \\ 83 \\ \text{Bi} \end{array}$ Bismuth | $\begin{array}{c} 210 \\ 84 \\ \text{Po} \end{array}$ Polonium | $\begin{array}{c} 210 \\ 85 \\ \text{At} \end{array}$ Astatine | $\begin{array}{c} 222 \\ 86 \\ \text{Rn} \end{array}$ Radon | | | |
| $\begin{array}{c} 223 \\ 87 \\ \text{Fr} \end{array}$ Francium | $\begin{array}{c} 226 \\ 88 \\ \text{Ra} \end{array}$ Radium | $\begin{array}{c} 227 \\ 89 \\ \text{Ac} \end{array}$ Actinium | | | | | | | | | | | | | | | | | | |

Key:

